



**Translation of the Original
Operating Manual**

**GA 5000EACIC
GA 5000EACEC**

Version 09/2016

**Electrostatic Air Spray Gun
for automatic operation
for flat or round jet nozzles**

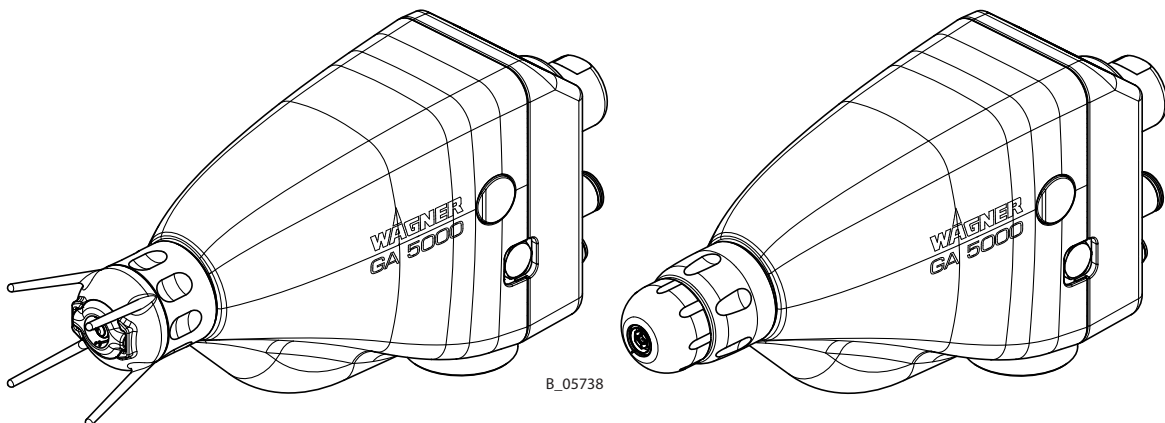

Contents

1	ABOUT THESE INSTRUCTIONS	7
1.1	Preface	7
1.2	Warnings, Notices and Symbols in these Instructions	7
1.3	Languages	8
1.4	Abbreviations	8
1.5	Terminology for the Purpose of this Manual	9
2	CORRECT USE	10
2.1	Device Type	10
2.2	Type of Use	10
2.3	Use in an Explosion Hazard Area	10
2.4	Safety Parameters	10
2.5	Processible Working Materials	11
2.6	Reasonably Foreseeable Misuse	12
2.7	Residual Risks	12
3	IDENTIFICATION	13
3.1	CE Explosion Protection Identification	13
3.2	Special Notice "X"	13
3.3	Identification "X" (Type Examination Certificate)	14
3.4	Type Plate	15
4	GENERAL SAFETY INSTRUCTIONS	16
4.1	Safety Instructions for the Operator	16
4.1.1	Electrical Equipment	16
4.1.2	Personnel Qualifications	16
4.1.3	Safe Work Environment	16
4.2	Safety Instructions for Staff	17
4.2.1	Safe Handling of WAGNER Spray Devices	17
4.2.2	Grounding the Device	18
4.2.3	Product Hoses	18
4.2.4	Cleaning and Flushing	19
4.2.5	Handling Hazardous Liquids, Varnishes and Paints	20
4.2.6	Touching Hot Surfaces	20
4.3	Protective and Monitoring Equipment	20
4.4	Use in Areas Subject to Explosion Hazards	21
4.4.1	Safety Regulations	21
4.5	Setting up Stationary Electrostatic Systems	21
4.6	Safety-Relevant Information about Discharges	22
5	DESCRIPTION	23
5.1	Structure (Standard Variant)	23
5.1.1	GA 5000EACIC Design	23
5.1.2	GA 5000EACEC Design	24
5.2	Mode of Operation	25
5.2.1	GA 5000EACIC Mode of Operation	25
5.2.2	GA 5000EACEC Mode of Operation	26
5.3	Protective and Monitoring Equipment	27
5.4	Scope of Delivery	27

Table of Contents

5.5	Technical Data	28
5.5.1	GA 5000EAC Dimensions	29
5.6	The WAGNER Electrostatic AirCoat Spraying System	30
5.6.1	Spraying Procedure for AirCoat Round Jet	31
5.6.2	Spraying Procedure for AirCoat Flat Jet	31
5.6.3	Electrostatic Effect	32
6	ASSEMBLY AND COMMISSIONING	33
6.1	Training Assembly/Commissioning Staff	33
6.2	Storage Conditions	33
6.3	Installation Conditions	33
6.4	Assembly and Installation	34
6.4.1	Typical Electrostatic Spraying System	34
6.4.2	Connecting GA 5000EACIC	36
6.4.3	Connecting GA 5000EACEC	37
6.4.4	Ventilation of the Spray Booth	38
6.4.5	Air Supply	39
6.4.6	Product Supply	39
6.4.7	Grounding	40
6.5	Preparation of Lacquer	42
6.5.1	Viscosity Conversion Table	42
6.6	Commissioning	43
6.6.1	Safety Instructions	43
6.6.2	Preparation for Commissioning	43
6.6.3	Commissioning	43
6.7	Verifying a Safe Operational Condition	44
7	OPERATION	45
7.1	Training the Operating Staff	45
7.2	Safety Instructions	45
7.2.1	Emergency Deactivation	46
7.2.2	General Rules for Making Adjustments to the Spray Gun	46
7.3	Working	47
7.3.1	Setting the Spray Pattern Using the Air Pressure Regulator	47
7.3.2	Spraying	48
7.3.3	Pressure Relief/Work Interruption	49
7.3.4	Dismantling the Gun Cover	50
7.3.5	Flushing Out Clogged Round Jet Nozzles	51
7.3.6	Replacing Round Jet Nozzle's Nozzle Insert	51
7.3.7	Changing from AirCoat Round Jet to AirCoat Flat Jet	52
7.3.8	Replacing the AirCoat Flat Jet Nozzles	54
7.3.9	Cleaning of the Nozzle Parts	55
7.3.10	Eliminate Nozzle Clogging	56
7.3.11	Changing the Valve Housing	58

Table of Contents

8	CLEANING AND MAINTENANCE	59
8.1	Cleaning	59
8.1.1	Cleaning Staff	59
8.1.2	Safety Instructions	59
8.1.3	Cleaning and Flushing the Device	61
8.2	Maintenance	63
8.2.1	Maintenance Staff	63
8.2.2	Safety Instructions	63
8.2.3	Safety Checks	64
8.2.4	Product Hoses, Tubes and Couplings	65
9	TROUBLE SHOOTING AND RECTIFICATION	66
10	REPAIR WORK	67
10.1	Repair Staff	67
10.2	Safety Instructions	67
10.3	Spray Gun	68
10.3.1	Tools	68
10.3.2	Dismantling of the Spray Gun	69
10.3.3	Cleaning the Parts After Disassembly	74
10.3.4	Assembling the Spray Gun	75
11	FUNCTION TEST AFTER THE REPAIR	82
11.1	Checking the High Voltage	82
11.2	Air Test	84
11.3	Product Pressure Test	84
11.4	Test of Spray Pattern	84
12	DISPOSAL	85
13	ACCESSORIES	86
13.1	Round Jet Nozzles	86
13.1.1	ACR 5000 Round Jet Nozzle Attachment	86
13.1.2	AirCoat Round Jet Nozzle Inserts	86
13.2	Flat Jet Nozzles	86
13.2.1	ACF 5000 Air Caps (Flat Jet)	86
13.2.2	ACF5000 AirCoat Flat Jet Nozzles	87
13.3	Filter	89
13.4	Electric Cables and Hoses	89
13.4.1	Gun Cable	89
13.4.2	Extension Cable for Gun Cable	89
13.4.3	Product Hoses, Standard	90
13.4.4	Product Hoses, LowR	90
13.4.5	Product Hose, 1.5 mm	90
13.4.6	Air Hoses	91
13.5	Miscellaneous	92

Table of Contents

14	SPARE PARTS	94
14.1	How Can Spare Parts Be Ordered?	94
14.2	GA 5000EACIC Spray Gun	95
14.2.1	GA 5000EAC – Adapter	98
14.3	GA 5000EACEC Spray Gun	100
14.4	Accessories Spare Parts Lists	102
14.4.1	Flat Jet Nozzles	102
14.4.2	ACR 5000 Round Jet Nozzle Attachment	103
15	WARRANTY AND CONFORMITY DECLARATIONS	104
15.1	Important Notes Regarding Product Liability	104
15.2	Warranty Claim	104
15.3	EU Declaration of Conformity	105

1 ABOUT THESE INSTRUCTIONS

1.1 PREFACE

The operating manual contains information about safely operating, maintaining, cleaning and repairing the device.

The operating manual is part of the device and must be available to the operating and service personnel.

The device may only be operated by trained personnel and in compliance with this operating manual. Operating and service personnel should be instructed according to the safety instructions.

This equipment can be dangerous if it is not operated according to the instructions in this operating manual.

1.2 WARNINGS, NOTICES AND SYMBOLS IN THESE INSTRUCTIONS

Warning instructions in this operating manual highlight particular dangers to users and to the device and state measures for avoiding the hazard. These warning instructions fall into the following categories:

Danger - immediate risk of danger.

Non-observance will result in death or serious injury.

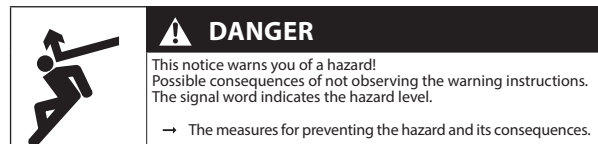

Warning - possible imminent danger.

Non-observance may result in death or serious injury.

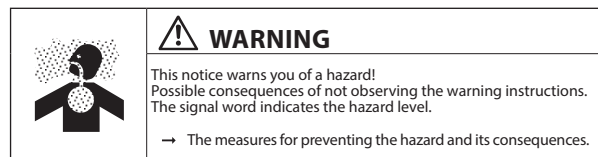

Caution - a possibly hazardous situation.

Non-observance may result in minor injury.

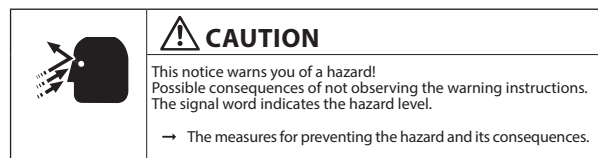

Notice - a possibly hazardous situation.

Non-observance may result in damage to property.

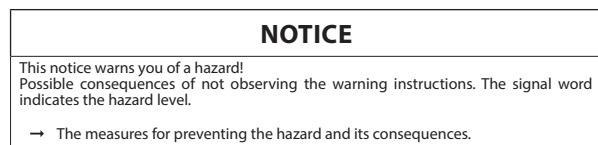

Note - provides information about particular characteristics and how to proceed.

1.3 LANGUAGES

The **GA 5000EAC** operating manual is available in the following languages:

Language	Order No.	Language	Order No.
German	2360921	English	2360922
French	2367694	Italian	2367695
Spanish	2367696		

Additional languages on request or at: www.wagner-group.com

1.4 ABBREVIATIONS

Order No.	Order number
ET	Spare part
K	Marking in the spare parts lists
GA	Automatic gun
EAC	Electrostatics Air Coat
IC	Shaping and atomizing air controlled via valve within gun
EC	Shaping and atomizing air controlled via valve outside of gun
Low R	Low-resistance
SSt	Stainless steel
Pos	Position
Stk	Number of pieces
SW	Wrench size

1.5 TERMINOLOGY FOR THE PURPOSE OF THIS MANUAL

Cleaning	Manual cleaning of devices and device parts with cleaning agent
Flushing	Internal flushing of paint-wetted parts with flushing agent

Staff qualifications

Trained person	Is instructed in the tasks assigned to him/her, the potential risks associated with improper behavior as well as the necessary protective devices and measures.
Electrically trained person	Is instructed by an electrician about the tasks assigned to him/her, the potential risks associated with improper behavior as well as the necessary protective devices and measures.
Electrician	Can assess the work assigned to him/her and detect possible hazards based on his/her technical training, knowledge and experience in relevant provisions.
Skilled person in the context of DGUV 209-052	A person who, based on his/her technical training, experience and recent vocational experience, has sufficient technical knowledge in the area of electrostatic coating and is familiar with the relevant and generally accepted rules of technology so that he/she can inspect and assess the status of devices and coating systems based on workplace safety. → Additional requirements for skilled persons are given in the TRBS 1203 (2010/Revision 2012): Expert knowledge in the areas of protection against excessive pressure, electrical hazards, and explosion protection (where applicable).

2 CORRECT USE

2.1 DEVICE TYPE

Electrostatic automatic spray gun for coating of grounded work pieces in automatic coating systems.

2.2 TYPE OF USE

The GA 5000EAC electrostatic automatic spray gun is suitable for spraying liquid products, particularly coating products. Coating products which contain ingredients of explosion class IIA and IIB substances (maximum ignition energy 0.24 mJ) may be used. WAGNER forbids any other use!

2.3 USE IN AN EXPLOSION HAZARD AREA

The GA 5000EAC electrostatic automatic spray gun is suitable for coating electrically conductive objects with liquid coating products and can be used in potentially explosive areas. Explosion Protection Identification (see Chapter 3)



2.4 SAFETY PARAMETERS

WAGNER accepts no liability for any damage arising from incorrect use.

- Use the device only to work with the products recommended by WAGNER.
- Only operate the device as a whole.
- Do not deactivate safety fixtures.
- Use only WAGNER original spare parts and accessories.

The device may only be operated under the following conditions:

- The operating personnel must be trained on the basis of this operating manual.
- The safety regulations listed in this operating manual must be observed.
- The operating, maintenance and repair information in this operating manual must be observed.
- The statutory requirements and accident prevention regulation standards in the country of use must be observed.

The electrostatic automatic spray gun may only be operated if all parameters are set and all measurements/safety checks are carried out correctly.

2.5 PROCESSIBLE WORKING MATERIALS

- Lacquers which contain ingredients of explosion class IIA and IIB substances (maximum ignition energy 0.24 mJ) can be processed with the GA 5000EAC spray gun.
- The spray gun basic version is suitable for processing sprayed substances with an electrical resistance of $> 150 \text{ k}\Omega$ (according to the WAGNER scale).
Equipped with a special product hose for low-resistance sprayed substances (available as an accessory), you can also successfully process sprayed substances with an electrical resistance $> 50 \text{ k}\Omega$ (according to the WAGNER scale).
- The application effectiveness is always dependant on the composition of the product being used, e.g., pigments or resin.

Conversion of Paint Resistance

There are paint resistance measuring devices available on the market that do not directly measure the specific paint resistance.

Multiplying the result of the measurement with the device-specific cell constant (K), we obtain the specific resistance value of the product.

Example:

With WAGNER's paint resistance measuring device the cell constant is $K = 123$.

Measured value according to the WAGNER scale $R = 500 \text{ k}\Omega$

Specific resistance (RS) $RS = R \times K = 500 \text{ k}\Omega \times 123 = 61.5 \text{ M}\Omega\text{-cm}$

Note:

Using sprayed substances with too low an electrical resistance, the application of electrostatics does not show any effect, i.e. there is no "paint wrap around" on the object to be sprayed.

The suitability of the spray product with regard to the charging ability can be read from the actual values for high voltage (kV) and for the spray current (μA) shown in the illuminated displays on the EPG 5000 control unit.

High kV value, low μA value = ok

Low kV value, high μA value = excessive conductivity of the paint

→ No wrap-around

- Please contact your local WAGNER dealer and the lacquer manufacturer if you encounter application problems.

2.6 REASONABLY FORESEEABLE MISUSE

The forms of misuse listed below may result in physical injury or property damage:

- use with non-authorized control units;
- coating work pieces which are not grounded;
- working with an ungrounded lacquer supply system;
- performing unauthorized conversions or modifications to the device;
- processing inadmissible coating products;
- processing dry or similar coating products, e.g., powder;
- using defective components, spare parts or accessories other than those described in the "Accessories" chapter of this operating manual;
- continuing work with a defective or kinked product hose;
- working with incorrectly set values;
- processing food.

2.7 RESIDUAL RISKS

Residual risks are risks which cannot be ruled out even in the event of correct use.

If necessary, warning and prohibition signs at the relevant points of risk indicate residual risks.

Residual risk	Source	Consequences	Specific measures	Lifecycle phase
Skin contact with lacquers and cleaning agents	Handling of lacquers and cleaning agents	Skin irritations, allergies	Wear protective clothing Observe safety data sheets	Operation, maintenance, disassembly
Lacquer in air outside the defined working area	Lacquering outside the defined working area	Inhalation of substances hazardous to health	Observe work and operation instructions	Operation, maintenance

3 IDENTIFICATION

3.1 CE EXPLOSION PROTECTION IDENTIFICATION

As defined in the Directive 2014/34/EU (ATEX), the device is suitable for use in potentially explosive areas.

Device type: GA 5000EAC electrostatic automatic spray gun
 Manufacturer: Wagner International AG
 CH-9450 Altstätten, Switzerland



CE ₀₁₀₂ Ex II 2 G 0.24mJ X SIRA 16 ATEX5290X
--

CE European Communities
 102 Notified body: PTB
 Ex Explosion-proof equipment
 II Device class II (not mining)
 2 Category 2 device (suitable for zone 1)
 G Ex-atmosphere gas
 0.24mJ Maximum ignition energy
 X Special Notes (see Chapter 3.2)
 SIRA 16 ATEX 5290X Number of type examination certificate

3.2 SPECIAL NOTICE "X"

Temperature notes

- Maximum surface temperature: 85 °C; 185 °F
- Maximum permissible product temperature: 50 °C; 122 °F
- Permissible ambient temperature: 0 to +40 °C; +32 to +104 °F



Cable connections

Only cable assigned to the device may be used (see Chapter 13).

Permissible Device Combinations

The GA 5000EAC automatic spray gun may only be connected to the control units listed below:

- EPG 5000 control unit

	 WARNING
	<p>Incorrect use! Risk of injury and damage to the device.</p> <p>→ Connect the GA 5000EAC automatic spray gun only to original WAGNER control units.</p>

3.3 IDENTIFICATION "X" (TYPE EXAMINATION CERTIFICATE)

Note:

The EC Type Examination Certificate from SIRA covers the following:

- use of the spray gun in Zone 1;
- use of the EPG 5000 control unit as related equipment for the spray gun.

3.4 TYPE PLATE

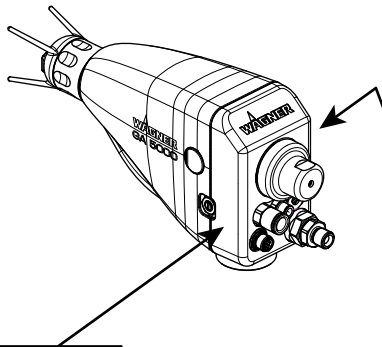

Wagner International AG
 CH-9450 Altstaetten
 GA 5000EACIC Art.Nr. 2357746
 high voltage: max. 80kV DC
 current: max. 100uA DC
 max. mat. pressure: 25MPa; 250bar; 3626psi
 max. air pressure: 0.8MPa; 8bar; 116psi

GA 5000EACIC

CE 0102 Ex II 2G 0.24mJ X
 SIRA 16 ATEX 5290X
 EN 50176:2009
 EN 50050-1:2013
 Ta = 0°C - 40°C, Temp code = T6

Wagner International AG
 CH-9450 Altstaetten
 GA 5000EACEC Art.Nr. 2360829
 high voltage: max. 80kV DC
 current: max. 100uA DC
 max. mat. pressure: 25MPa; 250bar; 3626psi
 max. air pressure: 0.8MPa; 8bar; 116psi

GA 5000EACEC

CE 0102 Ex II 2G 0.24mJ X
 SIRA 16 ATEX 5290X
 EN 50176:2009
 EN 50050-1:2013
 Ta = 0°C - 40°C, Temp code = T6

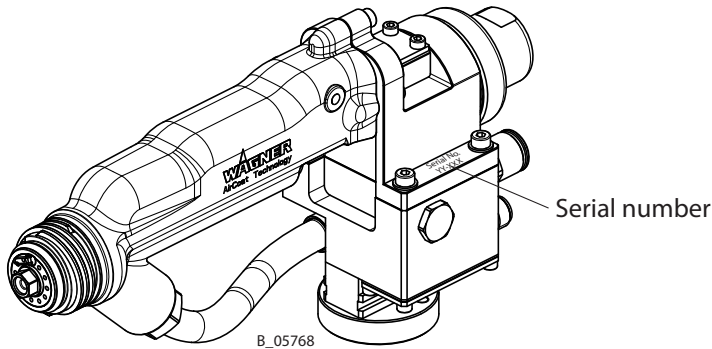

4 GENERAL SAFETY INSTRUCTIONS

4.1 SAFETY INSTRUCTIONS FOR THE OPERATOR

- Keep this operating manual at hand near the device at all times.
- Always follow local regulations concerning occupational safety and accident prevention.



4.1.1 ELECTRICAL EQUIPMENT

Electrical devices and equipment

- To be provided in accordance with the local safety requirements with regard to the operating mode and ambient influences.
- May only be maintained by skilled electricians or under their supervision. With open housings, there is a danger from line voltage.
- Must be operated in accordance with the safety regulations and electrotechnical regulations.
- Must be repaired immediately in the event of problems.
- Must be decommissioned if they pose a hazard or are damaged.
- Must be de-energized before work is commenced on active parts. Inform staff about planned work. Observe electrical safety regulations.
- Connect all devices to a common grounding point.
- Only operate the device with a properly installed socket with a protective ground wire connection.
- Keep liquids away from electrical devices.



4.1.2 PERSONNEL QUALIFICATIONS

- Ensure that the device is only operated, maintained and repaired by trained persons.

4.1.3 SAFE WORK ENVIRONMENT

- Ensure that the floor in the working area is static dissipative in accordance with EN 61340-4-1 (resistance must not exceed 100 megohms).
- Ensure that all persons within the working area wear static dissipative shoes. Footwear must comply with EN 20344. The measured insulation resistance must not exceed 100 megohms.
- If protective clothing is worn, including gloves, it has to comply with EN 1149-5. The measured insulation resistance must not exceed 100 megohms.
- Paint mist extraction systems/ventilation systems must be fitted on site according to local regulations.
- Ensure that the following components of a safe working environment are available:
 - Product/air hoses adapted to the working pressure.
 - Personal safety equipment (breathing and skin protection).

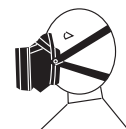

- Ensure that there are no ignition sources such as naked flames, sparks, glowing wires, or hot surfaces in the vicinity. No smoking.
- Ensure that the pipe joints, hoses, equipment parts and connections are permanently, technically leak-proof:
 - Periodic preventative maintenance and service (replacing hoses, checking tightness strength and connections etc.).
 - Regular monitoring of leaks and defects via visual inspection and odor testing, e.g., daily before commissioning, at the end of work or weekly.
- In the event of defects, immediately bring the device or system to a stop and arrange to have repairs carried out immediately.

4.2 SAFETY INSTRUCTIONS FOR STAFF

- Always follow the information in this manual, particularly the general safety instructions and the warning instructions.
- Always follow local regulations concerning occupational safety and accident prevention.
- Anyone fitted with a pacemaker must not enter the high-voltage area!



4.2.1 SAFE HANDLING OF WAGNER SPRAY DEVICES

The spray jet is under pressure and can cause dangerous injuries.

Avoid injection of paint or flushing agents:

- Never point the spray gun at people.
- Never reach into the spray jet.
- Before all work on the device, in the event of work interruptions and functional faults:
 - Switch off the energy/compressed air supply.
 - Relieve the pressure from the spray gun and device.
 - Secure the spray gun against actuation.
 - In the event of functional faults, remedy the fault as described in the "Troubleshooting" chapter.
- If necessary or at least every 12 months, the liquid ejection devices should be checked for safe working conditions by an expert (e.g., WAGNER Service Technician) in accordance with the guidelines for liquid ejection devices (DGUV regulation 100-500).
 - For shut down devices, the examination can be suspended until the next start-up.
- Carry out the work steps as described in the "Pressure relief" chapter:
 - If pressure relief is required.
 - If the spraying work is interrupted or stopped.
 - Before the device is cleaned on the outside, checked or serviced.
 - Before the spray nozzle is installed or cleaned.

In the event of skin injuries caused by paint or flushing agents:

- Note the paint or flushing agent that you have been using.
- Consult a doctor immediately.

4.2.2 GROUNDING THE DEVICE

Friction, flowing liquids and air or electrostatic coating processes create charges. Flames or sparks can form during discharge. Grounding prevents electrostatic charging.

- Ensure that the device is grounded. → See Chapter "Grounding".
- Ground the work pieces to be coated.
- Ensure that all persons inside the working area are grounded, e.g., that they are wearing static dissipative shoes.
- The spray substance supply (spray substance tank, pump, etc.) must be grounded.



4.2.3 PRODUCT HOSES

- Ensure that the hose material is chemically resistant to the sprayed products and the used flushing agents.
- Ensure that the product hose is suitable for the pressure generated.
- Ensure that the following information can be seen on the high-pressure hose:
 - Manufacturer
 - Permissible operating pressure
 - Date of manufacture
- Make sure that the hoses are laid only in suitable places. Hoses should not be laid in the following places under any circumstances:
 - in high-traffic areas,
 - on sharp edges,
 - on moving parts or
 - on hot surfaces.
- Ensure that the hoses are never run over by vehicles (e.g., fork lifts), or that the hoses are never put under pressure from the outside in any other way.
- Ensure that the hoses are never kinked. Observe maximum bending radii.
- Make sure that the hoses are never used to pull or move the equipment.
- Suction hoses may not be subjected to pressure.



Several liquids have a high expansion coefficient. In some cases their volume can rise with consequent damage to pipes, fittings, etc. and cause fluid leakage.

When the pump sucks liquid from a closed tank, ensure that air or a suitable gas can enter the tank. Thus a negative pressure is avoided. The vacuum could implode the tank (squeeze) and can cause it to break. The tank would leak and the liquid would flow out.

The pressure created by the pump is a multiplication of the inlet air pressure.

4.2.4 CLEANING AND FLUSHING

- Relieve the pressure from the device.
- De-energize the device electrically.
- Preference should be given to non-flammable cleaning and flushing agents.
- Observe the specifications of the lacquer manufacturer.
- Ensure that the flash point of the cleaning agent is at least 15 K above the ambient temperature or that cleaning is undertaken at a cleaning station with technical ventilation.
- Take measures for workplace safety (see Chapter 4.1.3).
- When commissioning or emptying the device, please note that an explosive mixture may temporarily exist inside the lines and components of equipment:
 - depending on the coating product used,
 - depending on the flushing agent (solvent) used,explosive mixture inside the lines and items of equipment.
- Only electrically conductive tanks may be used for cleaning and flushing agents.
- The tanks must be grounded.

An explosive gas/air mixture forms in closed tanks.

- Never spray into a closed tank when using solvents for flushing.

External cleaning

When cleaning the exterior of the device or its parts, also observe the following:

- Disconnect the pneumatic supply line.
- Use only moistened cloths and brushes. Never use abrasive agents or hard objects and never spray cleaning agents with a gun. Cleaning the device must not damage it in any way.
- Ensure that no electrical component is cleaned with nor even immersed into solvent.
- Which cleaning agent is used to clean the spray gun depends on which parts of the spray gun have to be cleaned and which product has to be removed. When cleaning the spray gun, only use **non-polar cleaning agents** to prevent conductive residues on the surface of the spray gun. Should it however, be necessary to use a polar cleaning agent, all residues of this cleaning agent have to be removed by using a non-conductive and non-polar cleaning agent, once the cleaning is finished.



4.2.5 HANDLING HAZARDOUS LIQUIDS, VARNISHES AND PAINTS

- When preparing or working with lacquer and when cleaning the device, follow the working instructions of the manufacturer of the lacquers, solvents and cleaning agents being used.
- Take the specified protective measures, in particular wear safety goggles, protective clothing and gloves, as well as skin protection cream if necessary.
- Use a mask or breathing apparatus if necessary.
- For sufficient health and environmental safety: Operate the device in a spray booth or on a spraying wall with the ventilation (extraction) switched on.
- Wear suitable protective clothing when working with hot products.



4.2.6 TOUCHING HOT SURFACES

- Only touch hot surfaces if you are wearing protective gloves.
- When operating the device with a coating product with a temperature of > 43 °C; 109.4 °F:
 - Identify the device with a warning label "Warning - hot surface".



Order No.

9998910 Instruction label

9998911 Protection label

Note: Order the two stickers together.

4.3 PROTECTIVE AND MONITORING EQUIPMENT

- Protective and monitoring equipment must not be removed, modified or rendered unusable.
- Regularly check for perfect functioning.
- If defects are detected on protective and monitoring equipment, the system must not be operated until these defects are remedied.

4.4 USE IN AREAS SUBJECT TO EXPLOSION HAZARDS

The spray gun may be used in potentially explosive areas. The following safety regulations must be observed and followed.



4.4.1 SAFETY REGULATIONS

→ Observe safety instructions in Chapter 3.2.

Safe handling of WAGNER spray devices

Mechanical sparks can form if the device comes into contact with metal.

In an explosive atmosphere:

- Do not knock or push the device against steel or rusty iron.
- Do not drop the spray gun.
- Use only tools that are made of a permitted material.

Ignition temperature of the coating product

→ Ensure that the ignition temperature of the coating product is above the maximum surface temperature.

Surface spraying, electrostatics

→ Never spray device parts using electrostatic equipment (electrostatic spray gun!).



Medium supporting atomizing

→ To atomize the product, use only weakly oxidizing gases, e.g., air.

Cleaning

If there are deposits on the surfaces, the device may form electrostatic charges. Flames or sparks can form during discharge.

- Remove deposits from the surfaces to maintain conductivity.
- Use only a damp cloth to clean the device.



4.5 SETTING UP STATIONARY ELECTROSTATIC SYSTEMS

The spray gun is a component of a stationary coating system. When setting up stationary coating systems, comply strictly with EN 50176. One of the requirements is that activation of the high voltage is only possible by using a key. But it must be possible to switch off the high voltage without a key.

4.6 SAFETY-RELEVANT INFORMATION ABOUT DISCHARGES

The plastic parts of the spray gun are charged electrostatically by the high-voltage field of the spray gun. Contact with plastic parts harmless discharges (brush discharges) may occur. They are completely non-hazardous for human health.

When keeping a distance of 4 to 10 mm; 0.15 to 0.4 inches between spray gun and object to be sprayed, the corona discharge at the end of the electrode is visible in the dark.

5 DESCRIPTION

5.1 STRUCTURE (STANDARD VARIANT)

5.1.1 GA 5000EACIC DESIGN

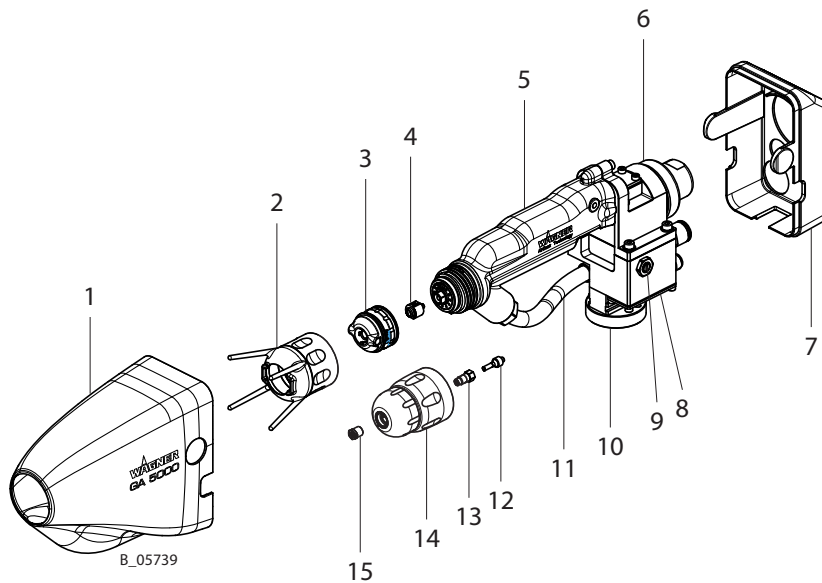

1	Front cover
2	Union nut with nozzle protection
3	Air cap
4	Flat jet nozzle
5	Gun adapter
6	Piston housing
7	Rear cover
8	Air diffuser housing

9	Shaping air setting
10	Gun holder
11	Product hose
12	Sealing fitting
13	Nozzle screw joint
14	Nozzle attachment
15	Round jet nozzle

Connections on the rear side:

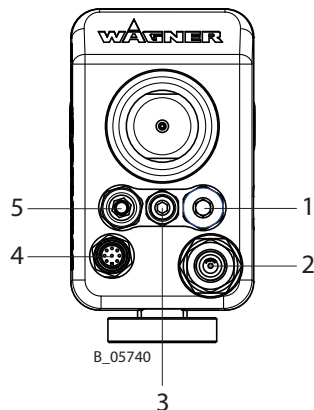

1	Connection closed with dummy plug
2	Product connection NPSM 1/4"
3	Control air connection (D6/red)
4	Gun cable connection
5	Shaping air or atomizing air connection (D10/blue)

5.1.2 GA 5000EACEC DESIGN

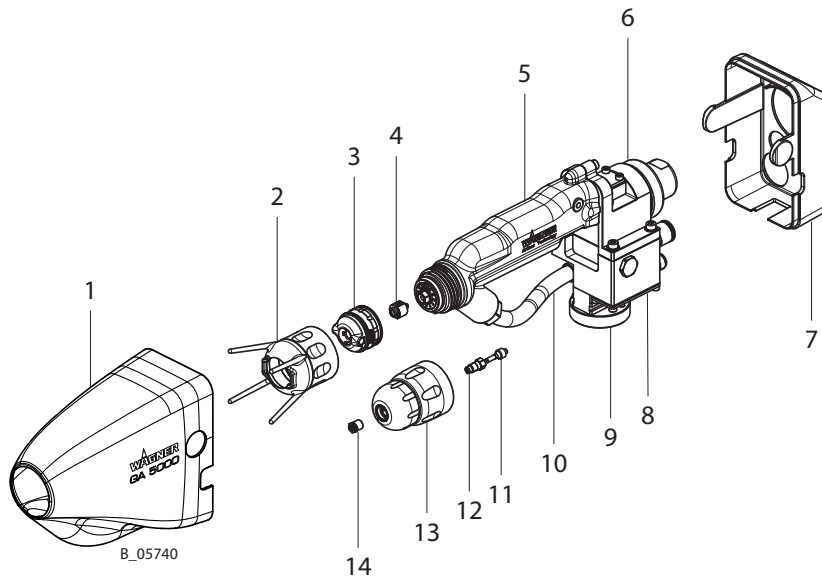

1	Front cover
2	Union nut with nozzle protection
3	Air cap
4	Flat jet nozzle
5	Gun adapter
6	Piston housing
7	Rear cover

8	Air diffuser housing
9	Gun holder
10	Product hose
11	Sealing fitting
12	Nozzle screw joint
13	Nozzle attachment
14	Round jet nozzle

Connections on the rear side:

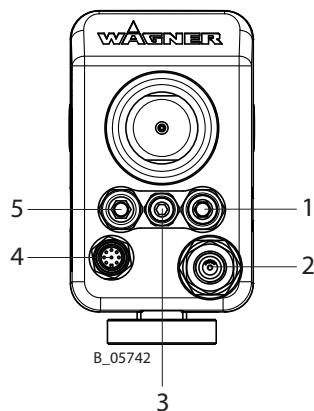

1	Atomizing air connection (D10/blue)
2	Product connection, G1/4"
3	Control air connection (D6/red)
4	Gun cable connection
5	Shaping air connection (D8/green)

5.2 MODE OF OPERATION

Note:

Operation of the spray gun in conjunction with the EPG 5000 control unit is described in this operating manual.

- The high voltage for the GA 5000EAC spray gun is activated directly on the EPG 5000 control unit or by a signal from the superordinate controller.
- The high voltage for the spray gun can be adapted via the voltage regulator on the EPG 5000 control unit and can be adjusted to the paint or to the spraying object.
- **Secure gun:**
 1. Switch off the mains at the EPG 5000
 2. Switch off the air supply at the EPG 5000
 3. Relieve the pressure of the spray gun and system

5.2.1 GA 5000EACIC MODE OF OPERATION

Pneumatic diagram:

SA = Shaping air
 AA = Atomizing air
 CA = Control air
 M = Product

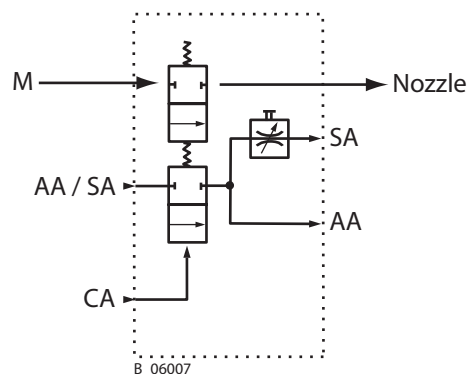

Open:

The piston in the drive is charged with control air and moves toward the rear. This ensures that the air valve which releases the shaping and atomizing air is opened first. The product valve is then opened with a mechanical delay. In this position, the pressurized coating product is applied to the work piece.

Close:

The piston is relieved, and the product valve closes due to the pressure spring which presses against the product valve tappet. The air valve is then closed, again with a spring force and mechanical delay.

Additional functions:

The shaping air throttle is used to regulate the shaping air volume, while the atomizing air is adjusted via an external pressure regulator. The two air streams do not flow separately until downstream of the air valve, so that the pressure of the shaping air corresponds roughly to that of the atomizing air and so that they influence each other during adjustment.

5.2.2 GA 5000EACEC MODE OF OPERATION**Pneumatic diagram:**

SA = Shaping air
 AA = Atomizing air
 CA = Control air
 M = Product

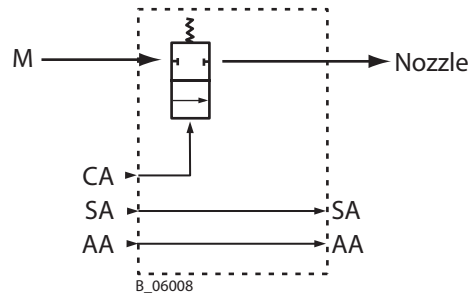
**Open:**

First, the external air valve, which enables the shaping and atomizing air, is opened. The diaphragm in the drive is then charged with control air and moves toward the rear, opening the product valve. In this position, the pressurized coating product is applied to the work piece.

Close:

If the control air is deactivated, the product valve closes due to the pressure spring. The air valve is then closed externally.



Additional functions:

The shaping air pressure and the atomizing air pressure are set externally via separate pressure regulators. Both air flows are supplied separately, which allows them to be set separately.

5.3 PROTECTIVE AND MONITORING EQUIPMENT

The following functions are provided for safety:

- Electrical monitoring of high voltage and spray current (maximum ignition energy 0.24 mJ)
 - No ignition danger and personnel danger
- Electrical monitoring of the spray gun
- Anti-contact guard for flat jet nozzle

	 WARNING
	<p>Protective and monitoring equipment! Risk of injury and damage to the device.</p> <ul style="list-style-type: none"> → Protective and monitoring equipment must not be removed, modified or rendered unusable. → Regularly check for perfect functioning. → If defects are detected on protective and monitoring equipment, the system must not be operated until these defects are remedied.

5.4 SCOPE OF DELIVERY

Order No.	Description
2360898	GA 5000EACIC spray gun
2360899	GA 5000EACEC spray gun
	The spray guns are delivered without control unit, product and air hose, electric cable, air cap and nozzle.

Each spray gun includes the following as standard equipment:

Order No.	Description
2309368	Valve needle assembly tool
2325263	Clamping screw assembly tool
2360925	Declaration of Conformity for ES 5000 Automatic
2360921	Operating manual German
see Chapter 1.3	Operating manual in local language

The spray gun basic version can be adapted optimally to any application depending upon the requirements and the desired accessories with the help of spray gun configuration.

The delivery note shows the exact scope of delivery.

5.5 TECHNICAL DATA

Control air pressure (open product valve)	0.4–0.8 MPa; 4–8 bar; 58–116 psi
Maximum atomizing air pressure	8 bar; 0.8 MPa; 116 psi
Maximum shaping air pressure	0.8 MPa; 8 bar; 116 psi
Maximum product pressure	250 bar; 25 MPa; 3626 psi
Input voltage	maximum 20 Vpp
Input current	maximum 1.0 A AC
Maximum output voltage	80 kV
Maximum output current	100 µA
Polarity	Negative
Maximum discharge energy	0.24 mJ
Product connection	NPSM 1/4"-18
Atomizer air connection	D10
Shaping air connection (only for GA 5000EACEC)	D8
Control air connection	D6
Weight (without houses)	1.0 kg; 2.2 lb
Flow rate	according to nozzle size (see nozzle table in "Accessories" chapter)
Ambient temperature	0 °C - 40 °C; 32 °F - 104 °F
Maximum product temperature	50 °C; 122 °F
Maximum surface temperature	85 °C; 185 °F
Compressed air quality: free from oil and water	Quality standard 6.5.2 according to ISO 8573.1, 2010 6: Particle density $\leq 5 \text{ mg/m}^3$ 5: Humidity: pressure dew point $\leq +7 \text{ °C}$ 2: Oil content $\leq 0.1 \text{ mg/m}^3$
Sound level at 0.3 MPa; 3 bar; 43.5 psi air pressure and 0.3 MPa; 3 bar; 43.5 psi product pressure *	76 dB(A)

* A-rated sound pressure level measured at 1 m distance, LpA1m, in accordance with DIN EN 14462: 2005.

5.5.1 GA 5000EAC DIMENSIONS

GA 5000EAC with flat jet nozzle

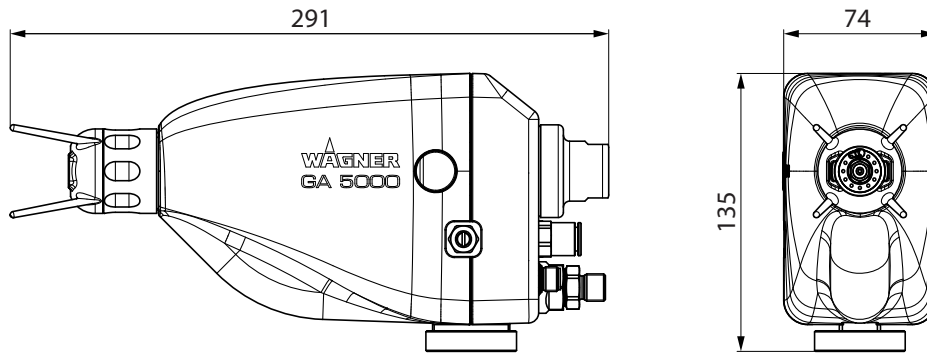

B_05748

GA 5000EAC with round jet nozzle

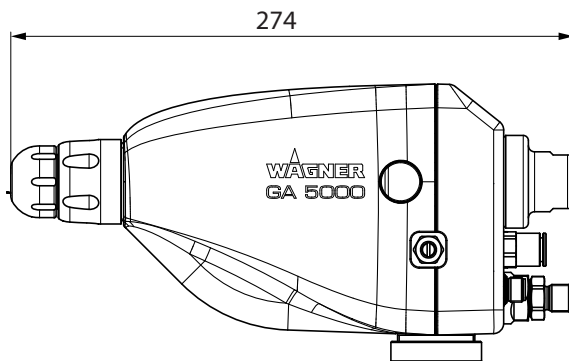

Connecting dimensions of the connection plate:

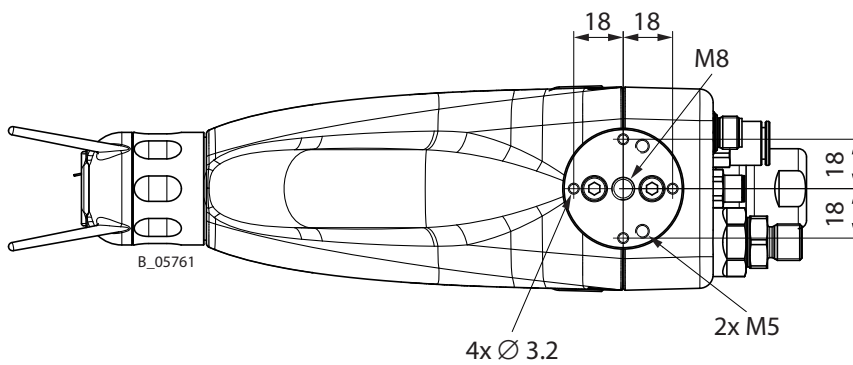

5.6 THE WAGNER ELECTROSTATIC AIRCOAT SPRAYING SYSTEM

The nozzle range (chapter 13) provided by WAGNER allows optimum coating results for any application.

General criteria for selection of nozzles

Flat jet → for large-surface parts

Round jet → for smaller delicate parts

Options for influencing the jet spray / spray pattern:

Description		Modification
Product pressure	P_{Mat}	+ or -
Atomizing air pressure	P_{ZL}	+ or -
Shaping air regulation	L_{FL}	from open to closed
Nozzle sizes	DS	Flow rate
Electrostatics	ES	+ or - or off

The spray jet width by GA 5000EACIC spray gun is adjusted via the shaping air regulation (A) on the gun and on the GA 5000EACEC spray gun via the air control knob (B) on the EPG 5000 control unit in the case of flat jet spraying.

GA 5000EACIC

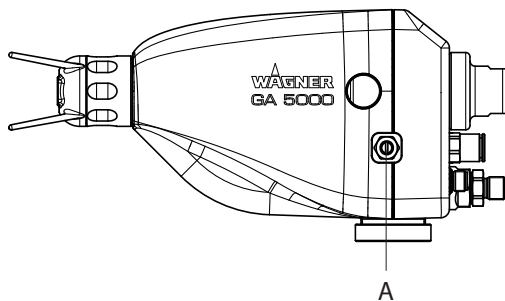

B_05769

GA 5000EACEC

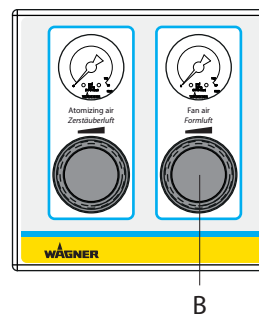

5.6.1 SPRAYING PROCEDURE FOR AIRCOAT ROUND JET

In the AirCoat process, the spray product is atomized under a pressure of 3-15 MPa; 30-150 bar; 435-2176 psi. With the help of an air pressure of 0-0.25 MPa; 0-2.5 bar; 0-36 psi, a soft, spray jet is produced. The spray jet diameter can be adjusted by turning the nozzle nut.

Advantages

- Large application volume
- Low fogging tendency
- Good finish
- High viscosity products can easily be applied
- High endurance of the nozzles
- Jet width adjustment

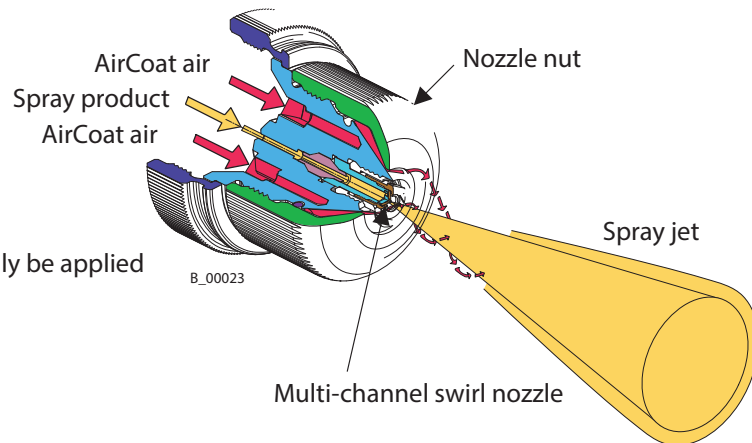

5.6.2 SPRAYING PROCEDURE FOR AIRCOAT FLAT JET

In the AirCoat process, the spray product is atomized under a pressure of 3-15 MPa; 30-150 bar; 435-2176 psi. With the help of the AirCoat air, with a pressure of 0-0.25 MPa; 0-2.5 bar; 0-36 psi, a soft, flat spray jet is produced which largely eliminates the problem of overlapping in the peripheral zones. With shaping air, there is the possibility of reducing the width of the spray jet.

Advantages

- Large application volume
- Low fogging tendency
- Good finish
- High viscosity products can easily be applied
- High endurance of the nozzles
- Jet width adjustment

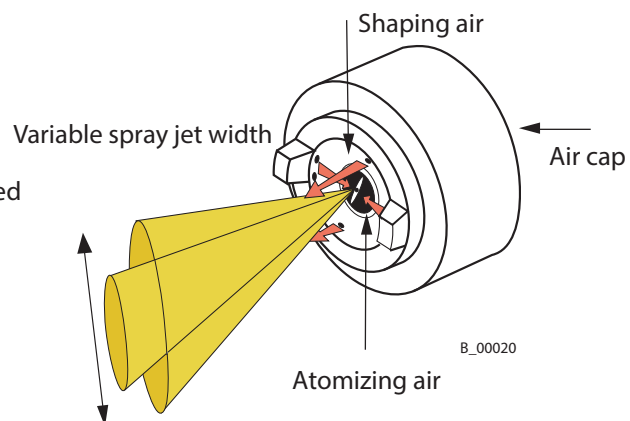

5.6.3 ELECTROSTATIC EFFECT

The spray gun produces an electrostatic field by means of the high-voltage electrode. As a result, the paint particles atomized by the spray gun are carried to the grounded work piece by kinetic and electrostatic energy, where they adhere finely dispersed to the object to be sprayed.

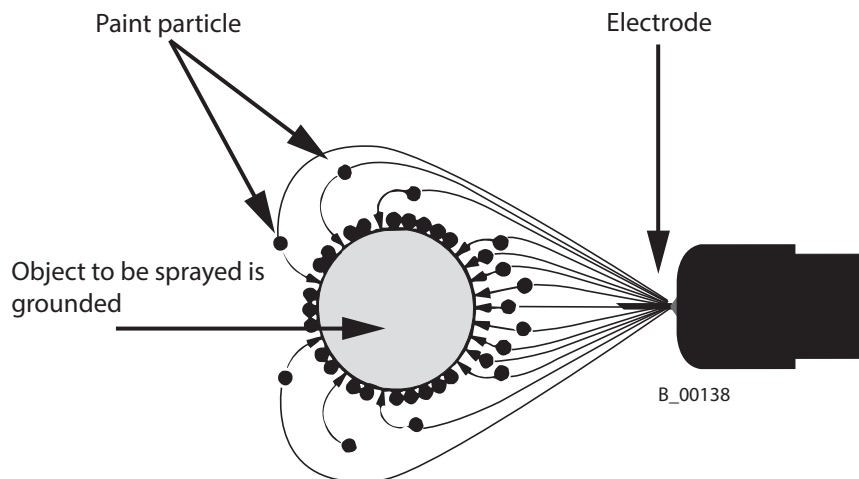



Advantages

- Very high application effectiveness
- Low over spray
- Coating of entire circumferences due to the electrostatic effect
- Savings in working time

6 ASSEMBLY AND COMMISSIONING

6.1 TRAINING ASSEMBLY/COMMISSIONING STAFF

	 WARNING
	<p>Incorrect installation/operation! Risk of injury and damage to the device.</p> <ul style="list-style-type: none"> → The assembly and commissioning staff must have the technical skills to safely commission the device. → When assembling, commissioning and carrying out all work, read and follow the operating manuals and safety regulations for the additionally required system components.

A skilled person must check to ensure that the device is in a reliable state after it is installed and commissioned.

6.2 STORAGE CONDITIONS

Until the point of assembly, the device must be stored in a dry location, free from vibrations and with a minimum of dust. The device must be stored in closed rooms.

The air temperature at the storage location must be between -20 °C and +60 °C (-4 °F and +140 °F).

The relative air humidity at the storage location must be between 10 and 95% (without condensation).

6.3 INSTALLATION CONDITIONS



The air temperature at the installation site must be in a range between 0 °C and 40 °C; 32 °F and 132 °F.

The relative air humidity at the installation site must be between 10 and 95% (without condensation).

6.4 ASSEMBLY AND INSTALLATION

6.4.1 TYPICAL ELECTROSTATIC SPRAYING SYSTEM

The GA 5000EAC spray gun must be combined with various components to make up a spraying system. The system shown in the figure is only one example of an electrostatic AirCoat spraying system. Your WAGNER distributor would be happy to assist you in creating a spraying system solution that meets your individual needs. You must familiarize yourself with the operating manuals and the safety regulations of all additional system components before starting commissioning.

	 WARNING
	<p>Incorrect installation/operation! Risk of injury and damage to the device.</p> <p>→ When commissioning and for all work, read and follow the operating manual and safety regulations for the additionally required system components.</p>

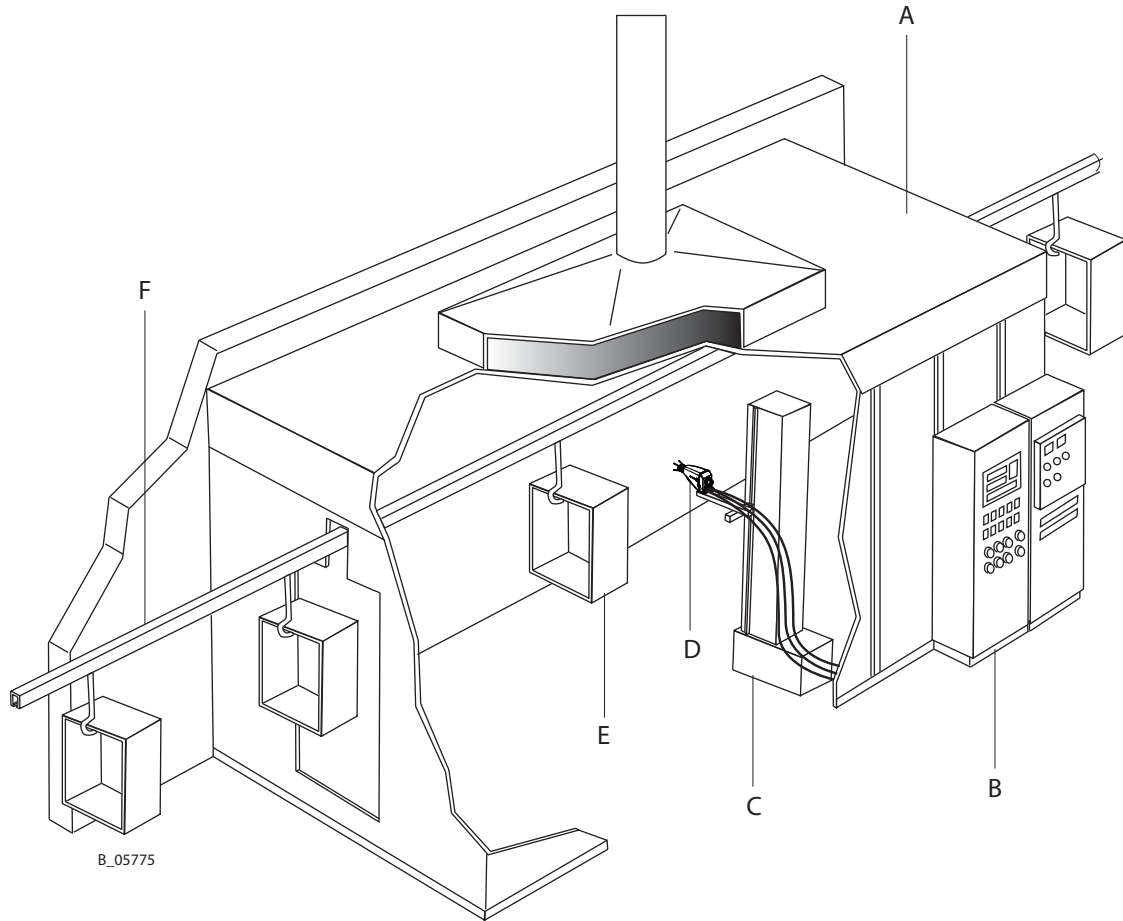

A	Spray booth
B	Controller
C	Reciprocator
D	Electrostatic spray gun
E	Work piece
f	Conveyor

6.4.2 CONNECTING GA 5000EACIC

	WARNING
	<p>Incorrect installation/operation! Risk of injury and damage to the device.</p> <p>→ When commissioning and for all work, read and follow the operating manual and safety regulations for the additionally required system components.</p>

Procedure:

1. Place the control unit outside the explosion zone.
2. Mount spray gun to an grounded gun mounting.
3. Connect the grounding cable to the control unit and the signal ground.
4. Connect the gun connection cable to the control unit.
5. Connect the control unit to the higher-level controller (if available).
6. Connect the air hoses to the control unit and the spray gun in accordance with the figure below.
7. Set all airs to "0" using the regulator on the front side of the control unit.
8. Connect the control unit to the compressed air supply.
9. Connect the spray gun to the product supply system.
10. Connect the control unit to the power supply.

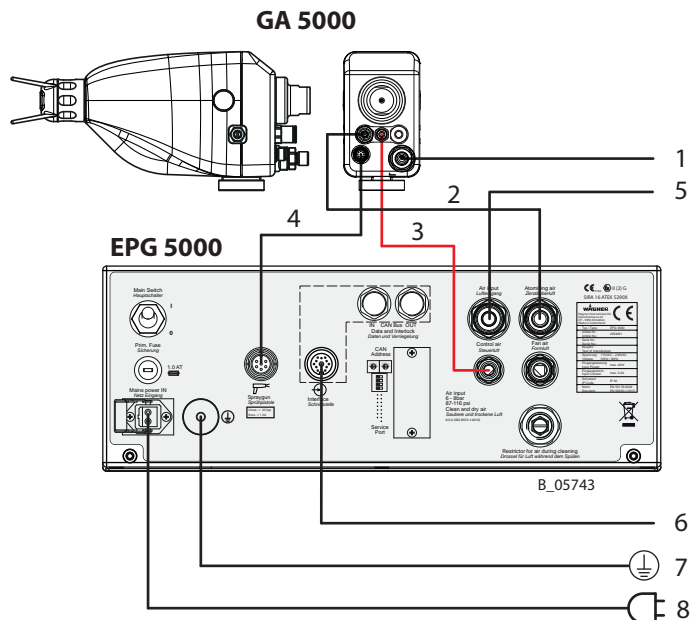

1	for the product supply system	4	Gun cable	7	Grounding cable
2	Shaping air and atomizing air hose	5	for the compressed air supply	8	Mains cable
3	Control air hose	6	Control cable		

6.4.3 CONNECTING GA 5000EACEC

	WARNING
	<p>Incorrect installation/operation! Risk of injury and damage to the device.</p> <p>→ When commissioning and for all work, read and follow the operating manual and safety regulations for the additionally required system components.</p>

Procedure:

1. Place the control unit outside the explosion zone.
2. Mount spray gun to an grounded gun mounting.
3. Connect the grounding cable to the control unit and the signal ground.
4. Connect the gun connection cable to the control unit.
5. Connect the control unit to the higher-level controller (if available).
6. Connect the air hoses to the control unit and the spray gun in accordance with the figure below.
7. Set all airs to "0" using the regulator on the front side of the control unit.
8. Connect the control unit to the compressed air supply.
9. Connect the spray gun to the product supply system.
10. Connect the control unit to the power supply.

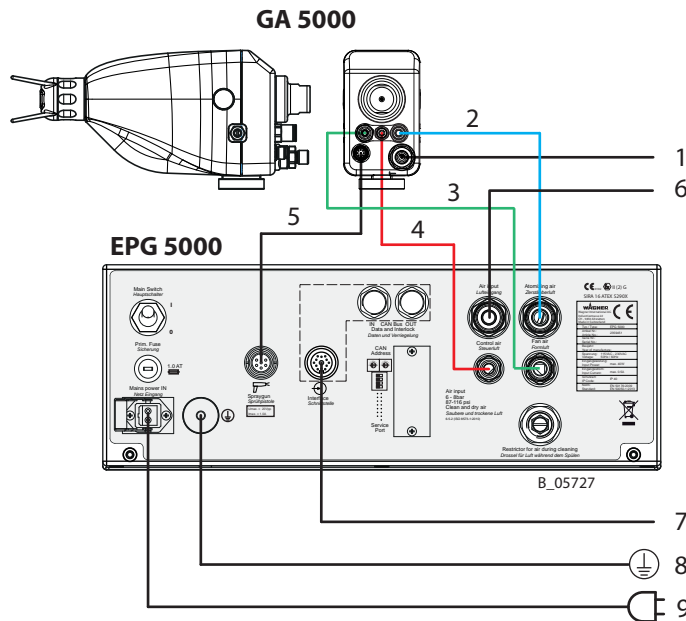



1	for the product supply system	4	Control air hose	7	Control cable
2	Shaping air hose	5	Gun cable	8	Grounding cable
3	Atomizing air hose	6	for the compressed air supply	9	Mains cable

6.4.4 VENTILATION OF THE SPRAY BOOTH



The electrostatic spraying equipment may only be operated in defined spraying areas and in accordance with the EN 12215 standard or under comparable ventilation conditions. The electrostatic spraying equipment must be locked to the technical ventilation so that the coating product supply and the high voltage are not effective as long as the technical ventilation is not operated with the minimum exhaust air volume flow or a larger exhaust air volume flow.

Ensure that the excess coating product (overspray) will be collected up safely.

	 WARNING
	<p>Toxic and/or flammable vapor mixtures! Risk of poisoning and burns.</p> <ul style="list-style-type: none">→ Operate the device in a spray booth approved for the working materials.-or-→ Operate the device on an appropriate spraying wall with the ventilation (extraction) switched on.→ Observe national and local regulations for the exhaust air speed.



6.4.5 AIR SUPPLY

The use of an air filter with air regulator ensures that only dry, clean atomizing air gets into the spray gun. Dirt and moisture in the atomizing air worsens the spraying quality and spray pattern.

	 WARNING
	<p>Hose connections! Risk of injury and damage to the device.</p> <p>→ Do not exchange hose connections of product hose and air hose.</p>

6.4.6 PRODUCT SUPPLY



NOTICE
<p>Impurities in the spraying system! Spray gun blockage, products harden in the spraying system.</p> <p>→ Flush the spray gun and paint supply with a suitable flushing agent.</p>



	 DANGER
	<p>Bursting hose, bursting threaded joints! Danger to life from injection of product.</p> <p>→ Ensure that the hose material is chemically resistant to the sprayed products.</p> <p>→ Ensure that the spray gun, threaded joints and product hose between the device and the spray gun are suitable for the pressure generated in the device.</p> <p>→ Ensure that the following information can be seen on the high-pressure hose:</p> <ul style="list-style-type: none"> - Manufacturer - Permissible operating pressure - Date of manufacture.

6.4.7 GROUNDING

Perfect grounding of all conductive parts such as floors, walls, roofs, barriers, work pieces, transport devices, coating product tank, coating product supply or construction parts in the spray area with exception of the high-voltage parts during normal operation is important for optimum coating and safety.

Parts of the booth must be grounded in accordance with EN 12215.

	 WARNING
	<p>Discharge of electrostatically charged components in atmospheres containing solvents! Explosion hazard from electrostatic sparks or flames.</p> <p>→ Ground all device components. → Ground the work pieces to be coated.</p>

	 WARNING
	<p>Heavy paint mist if grounding is insufficient! Danger of poisoning. Insufficient paint application quality.</p> <p>→ Ground all device components. → Ground the work pieces to be coated.</p>

A poorly grounded work piece causes:

- very bad wrap around,
- uneven coating,
- back spraying to the spray gun (contamination) and coater.

Prerequisites for perfect grounding and coating are:

- Clean work piece suspension.
- Grounding of spray booth, conveyor system and suspension on the building side in accordance with the operating manuals or the manufacturer's information.
- Grounding of all conductive parts within the working area.
- The grounding resistance of the work piece must not exceed 1 MΩ (megohm). (Resistance to ground measured at 500 V or 1000 V).
- Connect the control unit to the signal ground.
- Mount spray gun to an grounded gun mounting.
- Connect all ground cables using a short and direct route.
- Safety shoes must be static dissipative.

Grounding scheme (example)

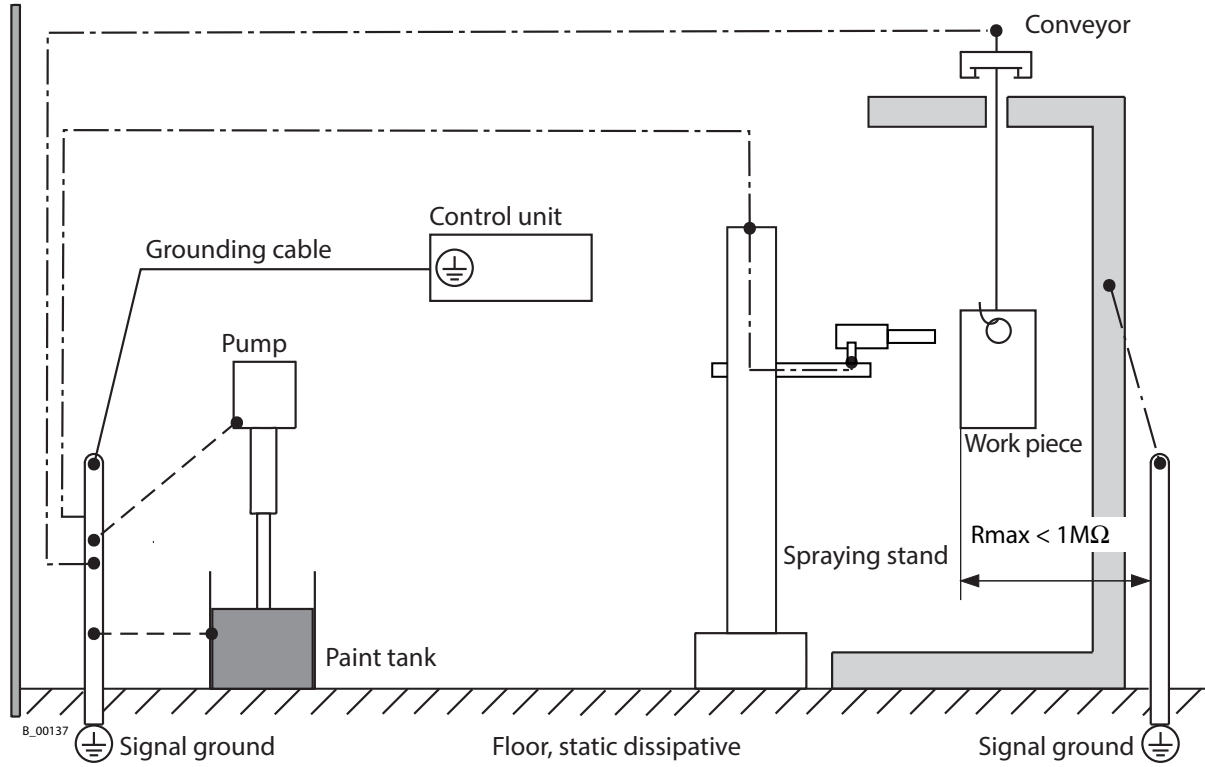

Minimum cable cross-section

Control unit	4 mm ² (AWG 12)
Pump	4 mm ² (AWG 12)
Paint tank	4 mm ² (AWG 12)
Reciprocator	16 mm ² (AWG 6)
Conveyor	16 mm ² (AWG 6)
Booth	16 mm ² (AWG 6)
Spraying stand	16 mm ² (AWG 6)

6.5 PREPARATION OF LACQUER

The viscosity of the lacquer is of great importance. The best spraying results are obtained with values between 25 and 40 DIN/4 seconds (measured in immersion flow cup DIN 4 mm; 0.16 inches).

Processing of up to 60 DIN/4 seconds is generally possible without problem if high coating thicknesses are required.

With the WAGNER AirCoat flat jet spraying process, the different viscosities of the lacquer are optimally covered by two air cap types. These can be found in "Accessories".

In the case of application problems contact the lacquer manufacturer.

6.5.1 VISCOSITY CONVERSION TABLE

mPa s	Centipoise	Poise	DIN Cup 4 mm 0.16 inch	Ford Cup 4	Zahn 2
10	10	0.1		5	16
15	15	0.15		8	17
20	20	0.2		10	18
25	25	0.25	14	12	19
30	30	0.3	15	14	20
40	40	0.4	17	18	22
50	50	0.5	19	22	24
60	60	0.6	21	26	27
70	70	0.7	23	28	30
80	80	0.8	25	31	34
90	90	0.9	28	32	37
100	100	1	30	34	41
120	120	1.2	33	41	49
140	140	1.4	37	45	58
160	160	1.6	43	50	66
180	180	1.8	46	54	74
200	200	2	49	58	82
220	220	2.2	52	62	
240	240	2.4	56	65	
260	260	2.6	62	68	
280	280	2.8	65	70	
300	300	3	70	74	
320	320	3.2			
340	340	3.4			
360	360	3.6	80		
380	380	3.8			
400	400	4	90		

6.6 COMMISSIONING

6.6.1 SAFETY INSTRUCTIONS

- Observe the safety instructions in Chapter 4 and Chapter 7.2.
- Observe the general rules for making adjustments to the spray gun → Chapter 7.2.2.

6.6.2 PREPARATION FOR COMMISSIONING

NOTICE

Impurities in the spraying system!

Spray gun blockage.

- Flush the spray gun and paint supply with a suitable flushing agent before commissioning.

6.6.3 COMMISSIONING

The following points should be noted before commissioning:

- Make sure that all other conductive parts within the work area are grounded.
- Lock the external release with the exhaust air unit.
- Lock the external release with an appropriate tool (e.g., key switch) (the high-voltage supply must be secured to prevent unauthorized persons from switching it on).
- Check that all product-conveying connections are correctly connected.
- Check that all air-conveying connections are correctly connected.
- Visually check the permissible pressures for all the system components.
- Check the level of the separating agent in the pump and fill up if necessary.
- Provide product tank, tanks for flushing agent and an empty tank for return flow.
- The interface on the rear of the control unit must be protected with a cover.
- Connect the system to the air supply.
- When first commissioning the unit → Flush the system in accordance with the operating manuals for the other components.

6.7 VERIFYING A SAFE OPERATIONAL CONDITION

A skilled person must check to ensure that the device and the spraying system are in a safe state after they are installed and commissioned.



This includes:

- Carry out a safety checks in accordance with Chapter 8.2.3.
- Function test in accordance with Chapter 11.





7 OPERATION



7.1 TRAINING THE OPERATING STAFF



	 WARNING
	<p>Incorrect operation! Risk of injury and damage to the device.</p> <ul style="list-style-type: none"> → The operating staff must be qualified to operate the entire system. → The operating staff must be familiar with the potential risks associated with improper behavior as well as the necessary protective devices and measures. → Before work commences, the operating staff must receive appropriate system training.

7.2 SAFETY INSTRUCTIONS

→ Observe safety instructions in Chapter 4.

	 WARNING
	<p>Incorrect operation! Risk of injury and damage to the device.</p> <ul style="list-style-type: none"> → If contact with lacquers or cleaning agents causes skin irritation, appropriate precautionary measures must be taken, e.g., wearing protective clothing. → The footwear worn by operating staff must comply with EN ISO 20344. The measured insulation resistance must not exceed 100 megohms. → The protective clothing, including gloves, must comply with EN ISO 1149-5. The measured insulation resistance must not exceed 100 megohms.

	 WARNING
	<p>Unintentional putting into operation! Risk of injury.</p> <p>Before any work on the device, in the event of work interruptions and malfunctions:</p> <ul style="list-style-type: none"> → Switch off the energy/compressed air supply. → Relieve the pressure from the spray gun and unit. → Secure the spray gun against actuation. → In the event of functional faults: remedy the fault as described in the "Troubleshooting" chapter.



	 WARNING
	<p>Discharge of electrostatically charged components in atmospheres containing solvents! Explosion hazard from electrostatic spark-over.</p> <p>→ Use gun only with fitted nozzle, air cap and union nut. → Tighten the union nut, especially with nozzle in the cleaning position.</p>



7.2.1 EMERGENCY DEACTIVATION

In the case of unforeseen occurrences, proceed as follows:

1. Switch off control unit.
2. Close the compressed air supply.
3. Relieve pressure according to the operating manual of the product pressure generator.

7.2.2 GENERAL RULES FOR MAKING ADJUSTMENTS TO THE SPRAY GUN

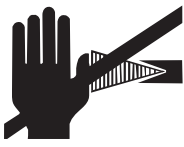
	 DANGER
	<p>High-voltage field! Danger to life from malfunction of heart pacemakers.</p> <p>Make sure that persons with pacemakers: → Do not work with the electrostatic spray gun. → Do not enter the high-voltage area.</p>

	 WARNING
	<p>High-pressure spray jet! Danger to life from injecting paint or solvent.</p> <p>→ Never reach into the spray jet. → Never point the spray gun at people. → Consult a doctor immediately in the event of skin injuries caused by paint or solvent. Inform the doctor about the paint or solvent used. → Never seal defective high-pressure parts; instead relieve the pressure from them and replace them immediately. → Wear the appropriate protective clothing, gloves, eyewear and respiratory protection.</p>

7.3 WORKING

7.3.1 SETTING THE SPRAY PATTERN USING THE AIR PRESSURE REGULATOR

The air pressure regulator regulates the air supply (shaping and atomizing air) to the gun.



Spray pattern and air regulation

When IC variant the air regulation regulates the ratio of shaping/atomizing air.

When IC variant the shaping and atomizing air are set individually.

The spray pattern can then be adjusted to suit the object being sprayed. The illustration shows the influence of the regulator on the spray pattern.

Other nozzle sizes can be used to obtain larger or smaller spray patterns.

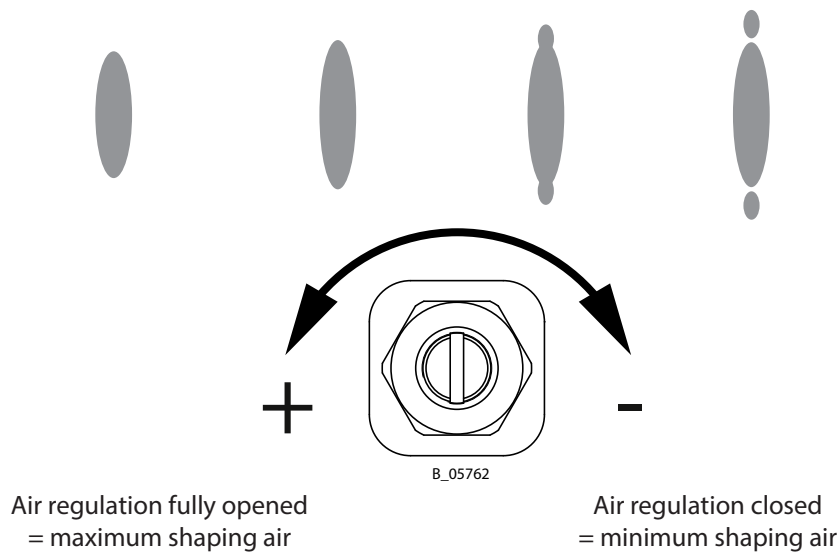

Changing the Flow Rate

- Adapt product pressure
- Use a different nozzle (see Chapter 13)

Changing the Spray Jet Width

- Use a different nozzle (see Chapter 13)

7.3.2 SPRAYING

1. Secure gun (switch off controller) and insert the desired nozzle.
2. Turn on the control unit. → See corresponding operating manual.
3. Start up with product supply set to approx. 8 MPa; 80 bar; 1160 psi operating pressure.
→ See corresponding operating manual.

AirLess spraying

4. Turn both air pressure regulators at the control unit all the way down.
5. Spray on a test object (switch on the controller).
6. Adjust the product pressure and gun air in accordance with the nozzle and object.

AirCoat spraying

7. When IC variant open the air pressure regulator (approx. 0.05–0.25 MPa; 0.5–2.5 bar; 7–36 psi) and adjust for optimal atomization.
When EC variant set shaping and atomizing air on the pressure regulators.

Flat-jet method: Changing the spray jet width

8. Change the spray jet width by selecting the appropriate nozzle.
By turning the air regulation (1), the spray jet can additionally be adjusted (IC variant).
Increase or decrease shaping air (EC variant)

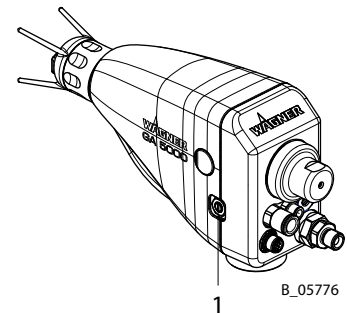

Round-jet method

8. By gently turning the nozzle nut (2), the atomizing air jet can additionally be adjusted.
→ **Do not fully tighten the nozzle nut:**
Do not turn the nozzle nut (2) until it is flush with the nozzle body (3). There must be play for the atomizing air between the nozzle nut and the nozzle body.

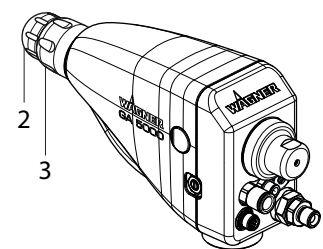

Flow rate



9. The flow rate can be reduced by:
 - Minimizing the product pressure.
 - Use a different nozzle (see Chapter 13).

7.3.3 PRESSURE RELIEF/WORK INTERRUPTION

The pressure must always be relieved when:

- The spraying tasks are finished.
- The spraying system is maintained.
- Cleaning tasks are carried out on the spraying system.
- The spraying system is moved to another location.
- Something must be checked on the spraying system.
- The valve seat is replaced on the gun.

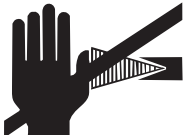
→ Observe general safety instructions in Chapter 4.

	 WARNING
	<p>High-pressure spray jet! Danger to life from injecting paint or solvent.</p> <ul style="list-style-type: none"> → Never reach into the spray jet. → Never point the spray gun at people. → Consult a doctor immediately in the event of skin injuries caused by paint or solvent. Inform the doctor about the paint or solvent used. → Never seal defective high-pressure parts; instead relieve the pressure from them and replace them. → Wear the appropriate protective clothing, gloves, eyewear and respiratory protection.

Process for relieving pressure

1. Switch off high voltage at the control unit.
2. Turn compressed air supply for shaping and atomizing air on the EPG 5000 to "0".
3. Close the compressed air supply on the material side upon the product pressure generator.
4. Relieve the pressure of gun and system, e.g., by switching on gun without high voltage.
5. Filling flushing agent.
6. Thoroughly flush out the spray gun.
7. Relieve the pressure on the gun and the system.
8. Clean gun and dry it with a cloth or a blow gun.

7.3.4 DISMANTLING THE GUN COVER



Note:

For changing nozzles, the cover does not have to be removed!

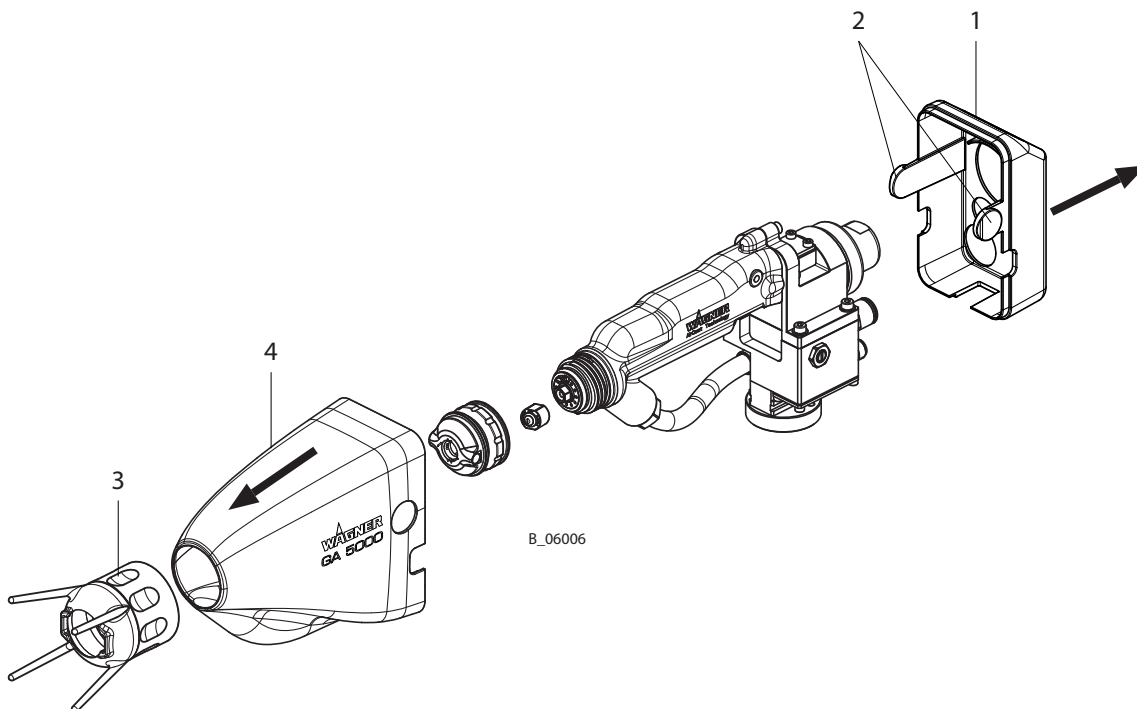
1. Press the snap fit (2) together and pull off the rear cover (1) to the back.
2. Unscrew union nut (3) and pull off front cover (4) to the front.



7.3.5 FLUSHING OUT CLOGGED ROUND JET NOZZLES

	 DANGER
	<p>Exploding gas / air mixture! Danger to life from flying parts and burns.</p> <p>→ Never spray into a closed tank. → Ground the tank.</p>

1. Remove nozzle insert (1) completely using nozzle spanner (2).
2. Actuate spray gun briefly.
3. Blow out and clean nozzle opposite the spraying direction.
4. After flushing, re-tighten the nozzle insert.

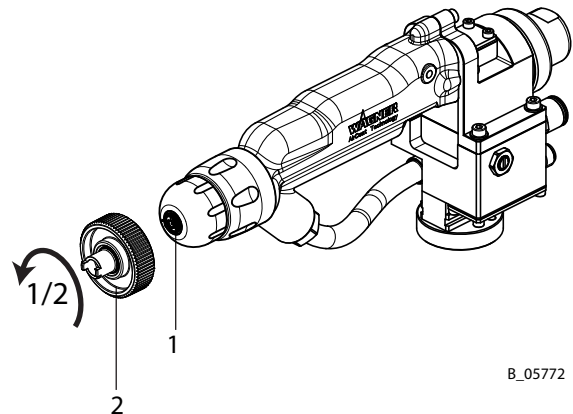
**7.3.6 REPLACING ROUND JET NOZZLE'S NOZZLE INSERT**

1. Remove nozzle insert (1) using nozzle spanner (2).
2. Assembling new nozzle insert.

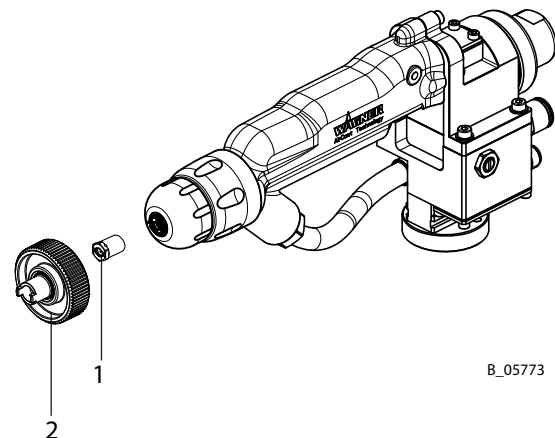

7.3.7 CHANGING FROM AIRCOAT ROUND JET TO AIRCOAT FLAT JET

Flush spray gun

1. Switch off control unit.
2. Relieve pressure → Chapter 7.3.3.
3. Connect the system to the flushing agent supply.
4. Set product pressure. Close air pressure regulator.
5. Thoroughly flush out the spray gun.
6. Relieve pressure → Chapter 7.3.3.

Changing from round jet to flat jet

7. Unscrew round jet nozzle attachment (2) incl. nozzle insert (3).
8. Unscrew nozzle insert (3) using nozzle spanner (4).
9. Unscrew nozzle nut (5). Remove nozzle screw joint (7) and sealing fitting (8) from the nozzle body (6). Thoroughly clean all parts.
10. Insert desired ACF5000 nozzle (11) into the valve housing.
11. Put the air cap (10) on the nozzle (11) and pay attention to the position of the guide surfaces.
12. Screw union nut with attached nozzle guard (9) to the gun body and make sure that the air cap horns lie in the designated recess (Y).
13. Before tightening with the air cap horns (Y), set the desired jet level and then tighten the union nut to stop by hand.

Changing from flat jet to round jet

7. Unscrew union nut (9) with air cap (10) and ACF5000 nozzle (11).
8. Remove air cap (10).
9. Press ACF5000 nozzle (11) out of air cap (10) by hand. Thoroughly clean all parts.
10. Insert nozzle screw connection (7) and sealing fitting (8) into nozzle body (6).
11. Screw nozzle nut (5) onto nozzle body (6).
Do not screw on nozzle nut completely. There must be play for the atomizing air between the nozzle nut and the nozzle body.
12. Screw on nozzle insert (3) using nozzle spanner (4).
13. Screw round jet nozzle attachment (2) with nozzle insert (3) onto spray gun and tighten by hand.

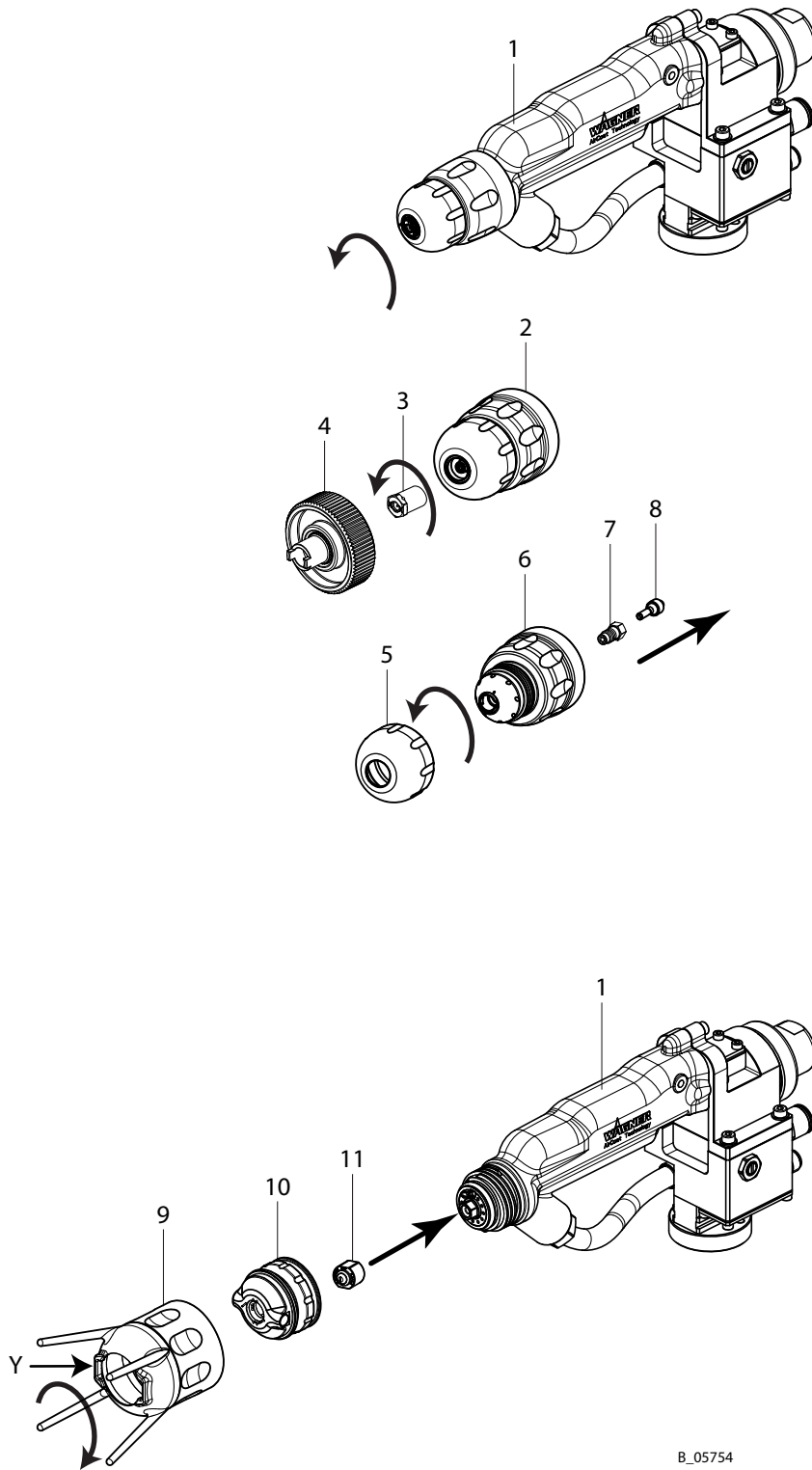

B_05754

7.3.8 REPLACING THE AIRCOAT FLAT JET NOZZLES

1. Switch off control unit.
2. Unscrew union nut completely (12) and remove air cap (10).
3. Remove and clean the ACF 5000 AirCoat nozzle (11).

NOTICE**Defective AirCoat nozzle!**

Insufficient paint application quality.

→ Do not use sharp-edged objects to treat carbide on the AirCoat nozzle.

4. Insert new ACF5000 nozzle (11) into the valve housing.
5. Put the air cap (10) on the nozzle (11) and pay attention to the position of the guide surfaces.
6. Screw union nut with attached nozzle guard (9) to the gun body and make sure that the air cap horns lie in the designated recess (Y).
7. Before tightening with the air cap horns (Y), set the desired jet level and then tighten the union nut to stop by hand.

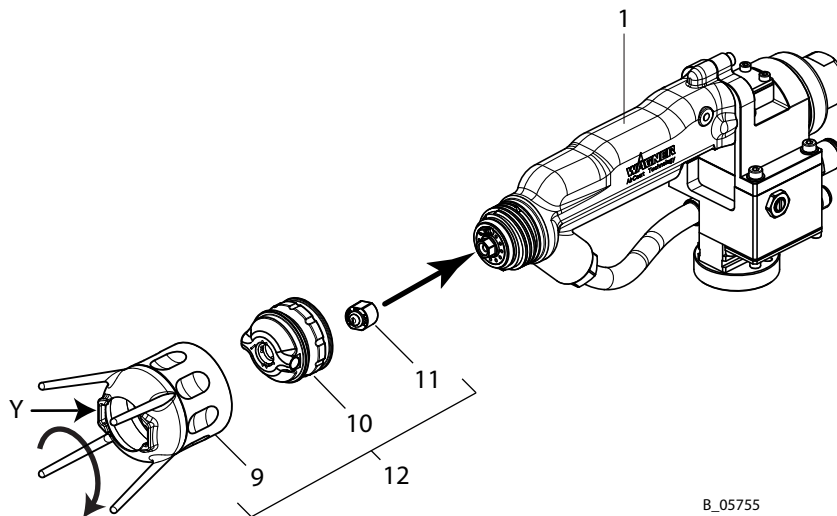

B_05755

7.3.9 CLEANING OF THE NOZZLE PARTS

The nozzle parts may only be immersed into a cleaning solvent recommended by the manufacturer and must be removed again immediately. They may only remain in a cleaning solvent for a short time.

Clean these parts with a brush and dry them with a cloth or a blow gun.

7.3.10 ELIMINATE NOZZLE CLOGGING

1. Switch control unit to standby operation.
2. Unscrew union nut completely (12) and remove air cap (10).
3. Push ACF 5000 nozzle (11) out of air cap (10) by hand, reverse it and put it into the air cap (10) with the nozzle tip towards the rear.
Pay attention to the position of the guide surfaces (X).
4. Insert air cap (10) with integrated ACF5000 nozzle (11) into the union nut (9).
Make sure that the air cap horns (Y) lie in the recess of the nozzle guard.
5. Screw preassembled union nut (12) to gun (1) and tighten by hand.
6. Switch on gun without high voltage and flush gun.
7. When the blockage has been flushed out, switch control unit back to standby operation.
8. Unscrew union nut (12) completely.
9. Remove air cap (10) and push ACF5000 nozzle (11) out of the air cap by hand.
Clean ACF5000 nozzle and insert it in the spraying position into the valve housing.
10. Put the air cap (10) on the nozzle (11) and pay attention to the position of the guide surfaces (X).
11. Screw union nut with attached nozzle guard (9) to the gun body and make sure that the air cap horns lie in the designated recess (Y).
12. Before tightening with the air cap horns (Y), set the desired jet level and then tighten the union nut to stop by hand.
13. Switch control unit to the required operating mode.

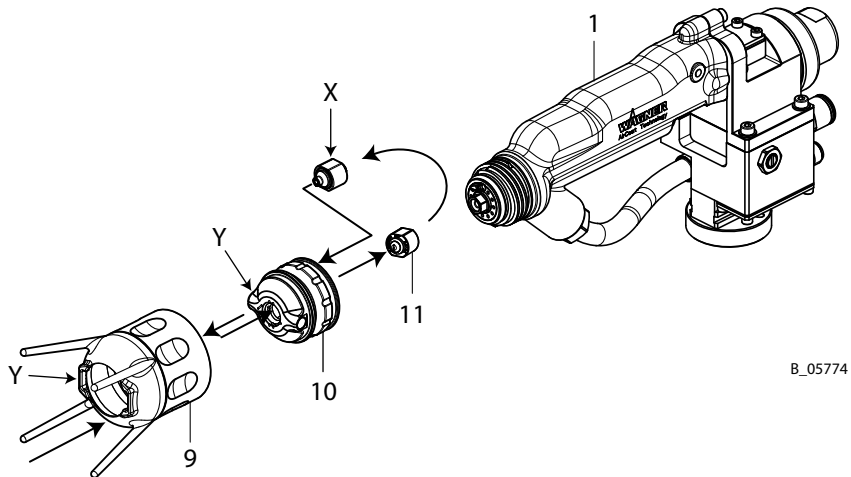

ACF5000 nozzle in **spray position**

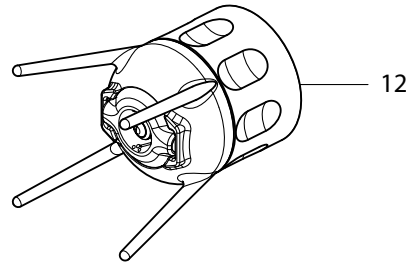
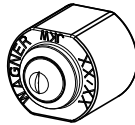

ACF5000 nozzle in **cleaning position**

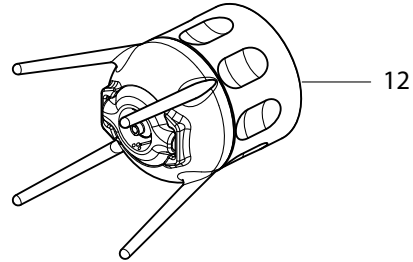
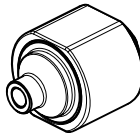

7.3.11 CHANGING THE VALVE HOUSING

Relieve pressure prior changing the valve housing. → Chapter 7.3.3

Use socket or ring spanner (no wrench)
to tighten the valve housing.

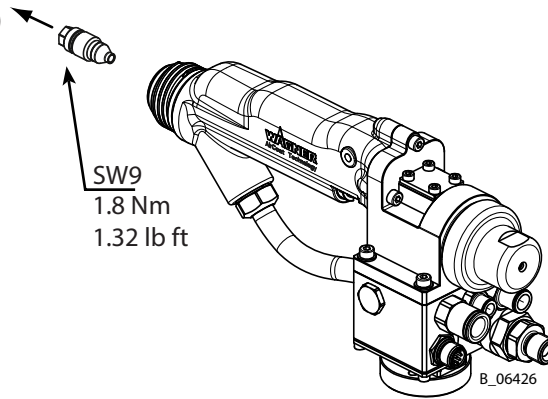

8 CLEANING AND MAINTENANCE

8.1 CLEANING

8.1.1 CLEANING STAFF



Cleaning work should be undertaken regularly and carefully by qualified and trained staff. They should be informed of specific hazards during their training.

The following hazards may arise during cleaning work:

- Health hazard from inhaling solvent vapors
- Use of unsuitable cleaning tools and aids

8.1.2 SAFETY INSTRUCTIONS

→ Observe safety instructions in Chapter 4.

	 DANGER
	<p>Incorrect maintenance/repair! Danger to life and equipment damage.</p> <ul style="list-style-type: none"> → Only a WAGNER service center or a suitably trained person may carry out repairs and replace parts. → Only repair and replace parts that are listed in the "Spare parts" chapter and that are assigned to the unit. → Before all work on the device and in the event of work interruptions: <ul style="list-style-type: none"> - Switch off the energy supply and the compressed air supply. - Relieve the pressure from the spray gun and device. - Secure the spray gun against actuation. → Observe the operating and service manual for all work.



DANGER



Explosive powder/air mixes!

Danger to life and equipment damage.

- Before starting cleaning, rinsing, or other manual work, the high voltage must be shut down and locked to prevent it from being switched back on!
- The spray gun must be separated from the high-voltage supply before any cleaning work is started!
- Only electrically conductive tanks may be used for cleaning and flushing agents. Ground the tank.
- Which cleaning agent is used to clean the spray gun depends on which parts of the spray gun have to be cleaned and which product has to be removed. When cleaning the spray gun, only use **non-polar cleaning agents** to prevent conductive residues on the surface of the spray gun. Should it however, be necessary to use a polar cleaning agent, all residues of this cleaning agent have to be removed by using a non-conductive and non-polar cleaning agent, once the cleaning is finished.
- Preference should be given to non-flammable cleaning and flushing agents.
- Only cleaning and flushing agents which contain ingredients of explosion classes IIA and IIB may be used (maximum ignition energy 0.24 mJ).
- The cleaning and flushing agent's flash point must be at least 15 K above the ambient temperature.
- Ensure that no electric component is cleaned with or immersed into solvent.



8.1.3 CLEANING AND FLUSHING THE DEVICE

The spraying system and the spray gun must be cleaned and flushed daily. The cleaning and flushing agents used must be compatible with the working material.

	 WARNING
	<p>Incompatibility of cleaning/flushing agent and working medium! Risk of explosion and danger of poisoning by toxic gases.</p> <p>→ Examine the compatibility of the cleaning and flushing agents and working media on the basis of the safety data sheets.</p>

NOTICE
<p>Damage to electrical devices!</p> <p>→ Never immerse the spray gun in cleaning agent.</p>

NOTICE
<p>Liquid in air tube! Functional faults caused by swollen seals. Discharge current to ground → No high voltage.</p> <p>→ Always point the spray gun down when cleaning. → Ensure that neither lacquers nor cleaning or flushing agent enters the air duct. → When taking a break from work or when stored for a longer period, the spray gun should be positioned with the adapter pointing downwards.</p>

	 DANGER
	Exploding gas / air mixture! Danger to life from flying parts and burns. → Never spray into a closed tank. → Ground the tank.

Clean nozzle

1. Switch off control unit.
2. Dismount nozzle and clean separately → Chapter 7.3.

Flush spraying system and spray gun

3. Connect spraying system to flushing agent supply in accordance with operating manual for the product pressure generator.
4. Point the spray gun toward the collection tray and switch it on. Switch off gun as soon as clean flushing agent emerges.
5. Remove flushing agent supply.

Blowing out the air passages of the spray gun

6. Close pump pressure regulator. Switch on compressed air supply on the control unit, open air pressure regulator for shaping and atomizing air.
7. Actuate the spray gun without activated high voltage and thoroughly blow out the air passages.
8. For switching off the shaping and atomizing air press the "Standby" button on the control unit.
9. Switch off the compressed air supply.

Clean the outside of the spray gun

10. Clean the spray gun body and other components of the spraying system with a cleaning agent recommended by the lacquer manufacturer and dry with a cloth or blow gun.

Cleaning the nozzle parts → see Chapter 7.3.9

Eliminating nozzle clogging → see Chapter 7.3.10

8.2 MAINTENANCE

8.2.1 MAINTENANCE STAFF

Maintenance work should be undertaken regularly and carefully by qualified and trained staff. They should be informed of specific hazards during their training.

The following hazards may arise during maintenance work:

- Health hazard from inhaling solvent vapors
- Use of unsuitable tools and aids

An authorized person must ensure that the device is checked for being in a reliable state after maintenance work is completed.

8.2.2 SAFETY INSTRUCTIONS

→ Observe the safety instructions in Chapter 4 and Chapter 8.1.2.

Prior to maintenance



- Flush and clean the system → Chapter 8.1.3.



After maintenance

- Carry out a safety checks in accordance with Chapter 8.2.3.
- Put the system into operation (Chapter 6.6) and check for leaks.
- Carry out a function test, if required, in accordance with Chapter 11.

→ In accordance with the guideline for liquid ejection devices (DGUV regulation 100-500):

- The liquid ejection devices should be checked by an expert (e.g., WAGNER service technician) for their safe working conditions as required and at least every 12 months.
- For shut down devices, the examination can be suspended until the next start-up.

	 DANGER
	<p>Incorrect maintenance/repair! Danger to life and equipment damage.</p> <p>→ Repair or replacement of devices or parts of devices are only allowed to be performed outside the hazard area by qualified personnel.</p>

	 DANGER
	<p>Incorrect maintenance/repair! Danger to life and equipment damage.</p> <ul style="list-style-type: none"> → Only a WAGNER service center or a suitably trained person may carry out repairs and replace parts. → Only repair and replace parts that are listed in the "Spare parts" chapter and that are assigned to the unit. → Before all work on the device and in the event of work interruptions: <ul style="list-style-type: none"> - Switch off the energy supply and the compressed air supply. - Relieve the pressure from the spray gun and device. - Secure the spray gun against actuation. → Observe the operating and service manual for all work.

8.2.3 SAFETY CHECKS



For the safe operation of stationary electrostatic spraying equipment for flammable liquid coating products, intervals for periodical inspections are defined as follows:

Inspection point	Inspection interval	Remarks
Gun cleaning, gun flushing	daily	Chapter 4.2.4, Chapter 8.1
Hoses, tubes, couplings	daily	Chapter 8.2.4
Grounding	weekly	Chapter 4.2.2, Chapter 6.4.7
Inspection for damage	weekly	Chapter 8.1.3, 8.2, 10
Locking of the technical ventilation with the electrostatic spraying equipment	annually	Chapter 6.4.4

The above recommended intervals are maximum values and may be modified by the operator depending on the local and operational conditions and the contamination.

Damaged devices must be decommissioned and repaired immediately.

8.2.4 PRODUCT HOSES, TUBES AND COUPLINGS

	 DANGER
	<p>Bursting hose, bursting threaded joints! Danger to life from injection of product and from flying parts.</p> <ul style="list-style-type: none"> → Ensure that the hose material is chemically resistant to the sprayed products and the used flushing agents. → Ensure that the spray gun, threaded joints, and product hose between the device and the spray gun are suitable for the generated pressure. → Ensure that the following information can be seen on the hose: <ul style="list-style-type: none"> - Manufacturer - Permissible operating pressure - Date of manufacture

The service life of the complete hoses between product pressure generator and application device is reduced due to environmental influences even when handled correctly.

- Check hoses, pipes, and couplings every day and replace if necessary.
- Before every commissioning, check all connections for leaks.
- Additionally, the operator must regularly check the complete hoses for wear and tear as well as for damage at intervals that he/she has set. Records of these checks must be kept.
- Undamaged complete hoses are to be replaced when one of the two following intervals has been exceeded:
 - 6 years from the date of the hose crimping (see fitting embossing).
 - 10 years from the date of the hose imprinting.

Fitting embossing (if present)	Meaning
xxx bar	Pressure
yymm	Crimping date (year/month)
XX	Internal code

Hose imprinting	Meaning
WAGNER	Name/Manufacturer
yymm	Date of manufacture (year/month)
xxx bar (xx MPa) e.g., 270 bar (27 MPa)	Pressure
XX	Internal code
DNxx (e.g., DN10)	Nominal diameter

9 TROUBLE SHOOTING AND RECTIFICATION

Functional fault	Cause	Remedy
Insufficient product output	Nozzle too small	Select larger nozzle (see "Accessories" chapter).
	Product pressure too low	Increase product pressure.
	Product pressure generator blocked	Clean or replace filter.
	Nozzle is clogged	Clean or replace nozzle.
Poor spray pattern	Wrongly adjusted atomizing air	Readjust the atomizing air.
	Unfavorable nozzle size	Select a different nozzle (see "Accessories" chapter).
	Product pressure too high/too low	Adapt product pressure.
	Spray product viscosity too high	Thin product in accordance with the manufacturer's instructions.
	Damaged nozzle	Attach new nozzle.
Poor wrap-around	Poor grounding at object	Check grounding of object or hanger with ohmmeter.
	Lacquer resistance too high/too low	Check paint resistance (see Chapter 2.5)
	Spraying pressure too high	Readjust spraying pressure.
No wrap-around	No high voltage	Switch on high voltage at the control unit. / Repair malfunction as explained in the control unit operating manuals.
		Connect gun and gun cable/check for defect.
		Check paint resistance (see Chapter 2.5)
	Seal in end piece defective	Repair by WAGNER Service Department.
	Air-passages damp	Clean and dry air passages.
Back-spray	Poor grounding at object	Check grounding.
	Distance between spray gun and object too large	Reduce distance between spray gun and work piece.
	High voltage set wrongly (too high)	Adapt high voltage to product.
	Loosen the nozzle union nut for round jet method	Tighten union nut by hand.
Valve seat leaks	Valve seat or valve tip worn	Replace valve seat or valve tip.

10 REPAIR WORK

10.1 REPAIR STAFF

Repair work should be undertaken carefully by qualified and trained personnel. They should be informed of specific hazards during their training.

The following hazards may arise during repair work:

- Health hazard from inhaling solvent vapors
- Use of unsuitable tools and aids

A skilled person must check to ensure that the device is in a reliable state after it is repaired. Carry out function test in accordance with Chapter 11.

10.2 SAFETY INSTRUCTIONS

→ Observe the safety instructions in Chapter 4 and Chapter 8.1.2.

Before a Repair

- Flush and clean the system → Chapter 8.1.3.

After a Repair

- Carry out a safety checks in accordance with Chapter 8.2.3.
- Put the system into operation (Chapter 6.7) and check for leaks.
- Function test in accordance with Chapter 11.

→ In accordance with the guideline for liquid ejection devices (DGUV regulation 100-500):

- The liquid ejection devices should be checked by an expert (e.g., WAGNER service technician) for their safe working conditions as required and at least every 12 months.
- For shut down devices, the examination can be suspended until the next start-up.



DANGER

Incorrect maintenance/repair!

Danger to life and equipment damage.

- Only a WAGNER service center or a suitably trained person may carry out repairs and replace parts.
- Only repair and replace parts that are listed in the "Spare parts" chapter and that are assigned to the unit.
- Before all work on the device and in the event of work interruptions:
 - Switch off the energy supply and the compressed air supply.
 - Relieve the pressure from the spray gun and device.
 - Secure the spray gun against actuation.
- Observe the operating and service manual for all work.

10.3 SPRAY GUN

Plastic parts

Gently handle all plastic parts.

10.3.1 TOOLS

For disassembling and assembling the spray gun, the following tools are required:

- Allen wrench, SW 3
- Wrench, SW 5
- Wrench, SW 7
- Wrench, SW 8
- Wrench, SW 19
- Wrench, SW 22
- Ring spanner, SW 9
- Slide gauge
- Valve needle assembly tool, Order No. 2309368
- Clamping screw assembly tool, Order No. 2325263

Brand notice:

The brands specified in this document are property of the respective owners. Loctite®, for example, is a registered brand of Henkel.

10.3.2 DISMANTLING OF THE SPRAY GUN

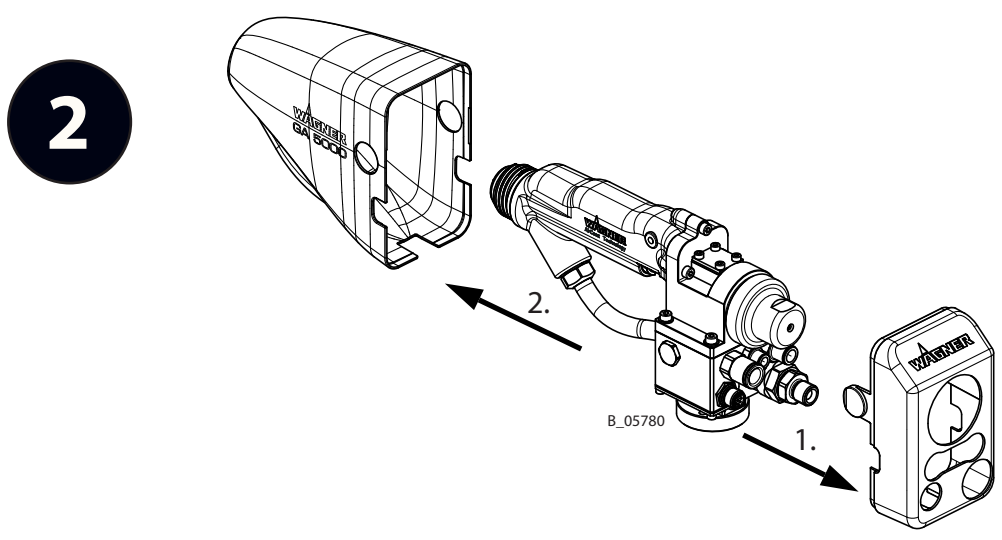
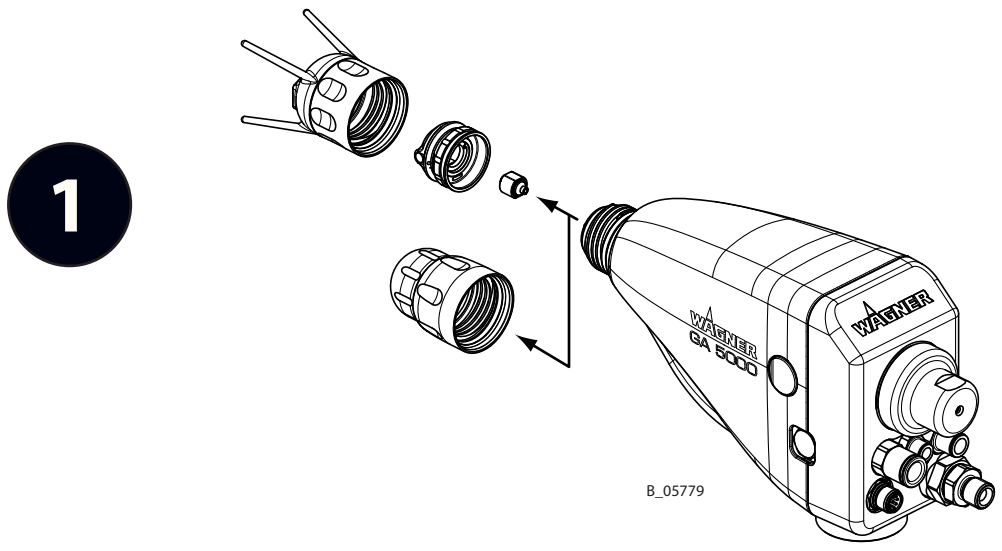

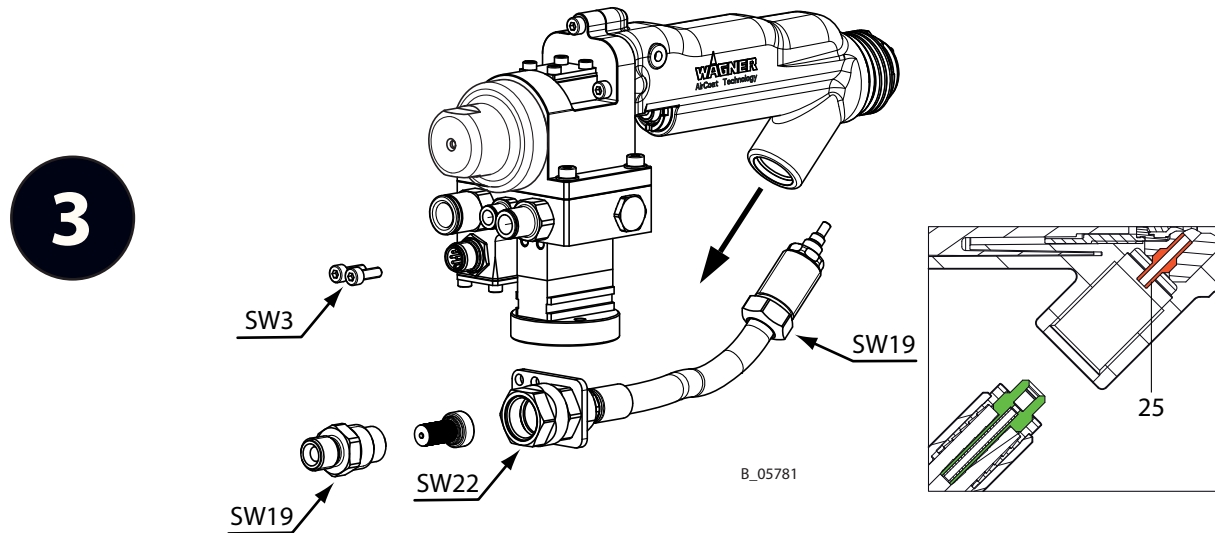
**Product hose:**

Do not tilt, but pull it straight out in direction indicated by arrow. At the same time, execute slight rotational movements.

Fitting (25), if fitting has any leaks:

If the fitting (25) does not come out with the product hose, it must be removed from the gun adapter as follows:

- Screw the wood screw (\varnothing 3 mm; 0.12 inches, length 40 mm; 1.6 inches) into the fitting (25), max. 6 mm deep.
- Pull out straight with suitable pliers. Possibly rotate clockwise simultaneously.
- Thereafter, the fitting must be replaced.

If the fitting is broken in the gun adapter, WAGNER Service Department must be contacted.

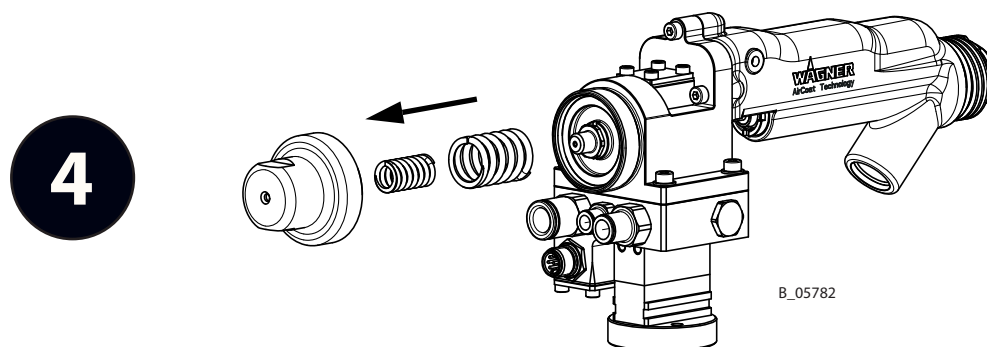

5

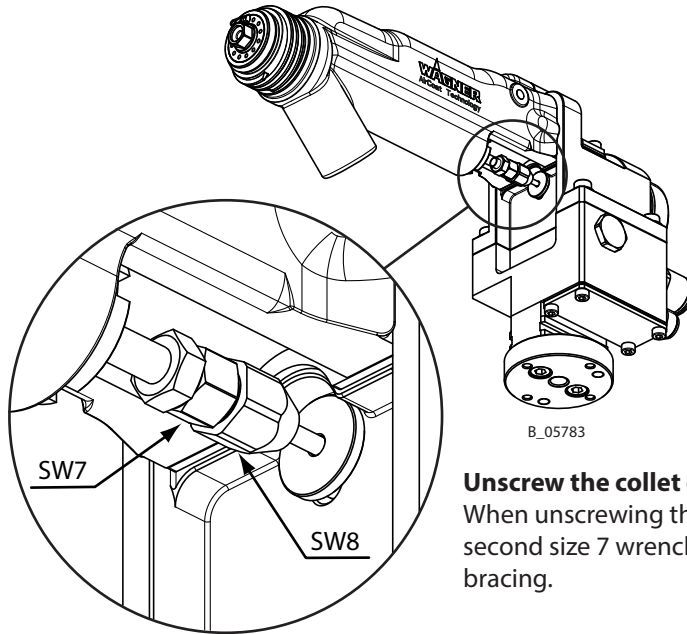

Unscrew the collet chuck:
When unscrewing the collet chuck, a second size 7 wrench must be used for bracing.

6

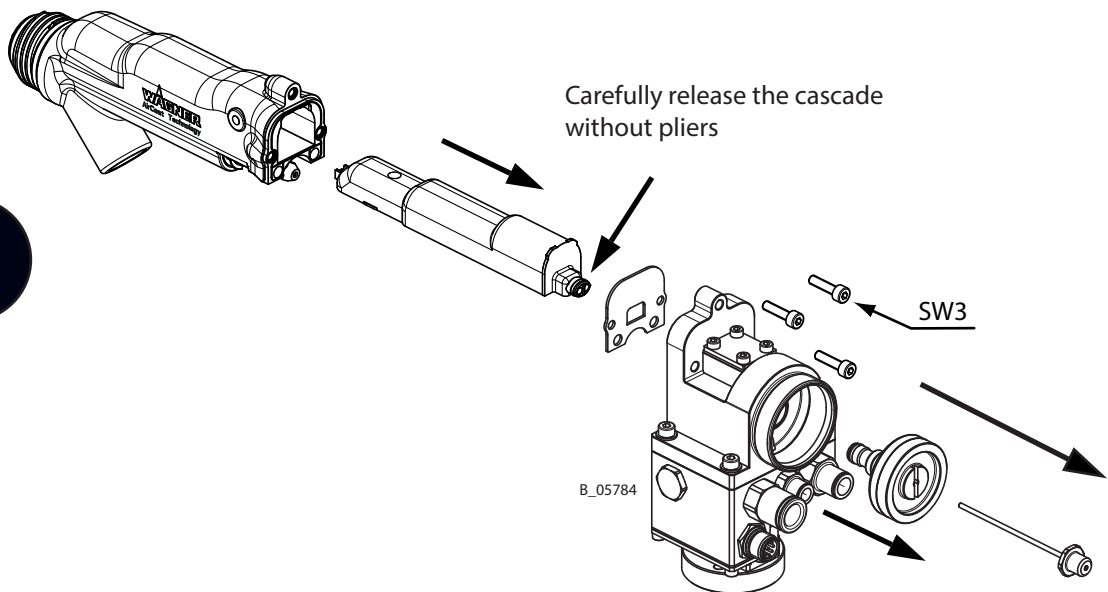

Carefully release the cascade without pliers

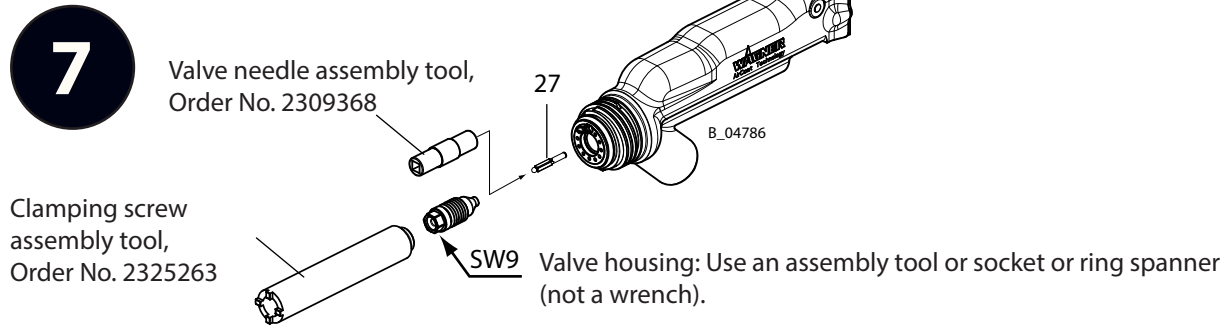

Valve tip (27)
Loosen valve tip by hand using the valve needle assembly tool (Order No. 2309368).

8

The gold contact sleeve (10) remains in adapter (11) or sits on resistance (12). Do not lose!
(The other gold contact sleeve is in the contacting (13)).

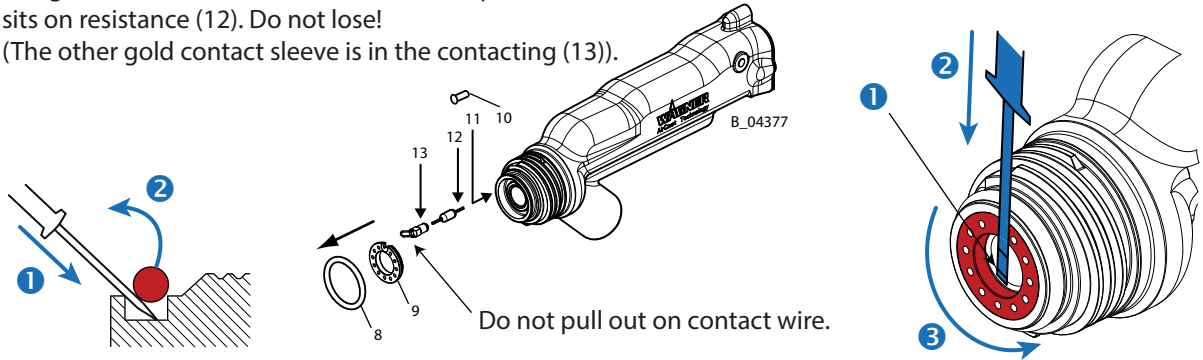

O-ring (8):
1. Use screwdriver no. 1 to press under the O-ring.
2. Lever up the O-ring and remove it.

Air manifold ring (9):
1. Locate the start of the thread for recessed internal threading.
2. Lever under the air distribution ring directly in front of the start of the thread using screwdriver no. 1.
3. As soon as the ring disengages, carefully undo it on all sides.

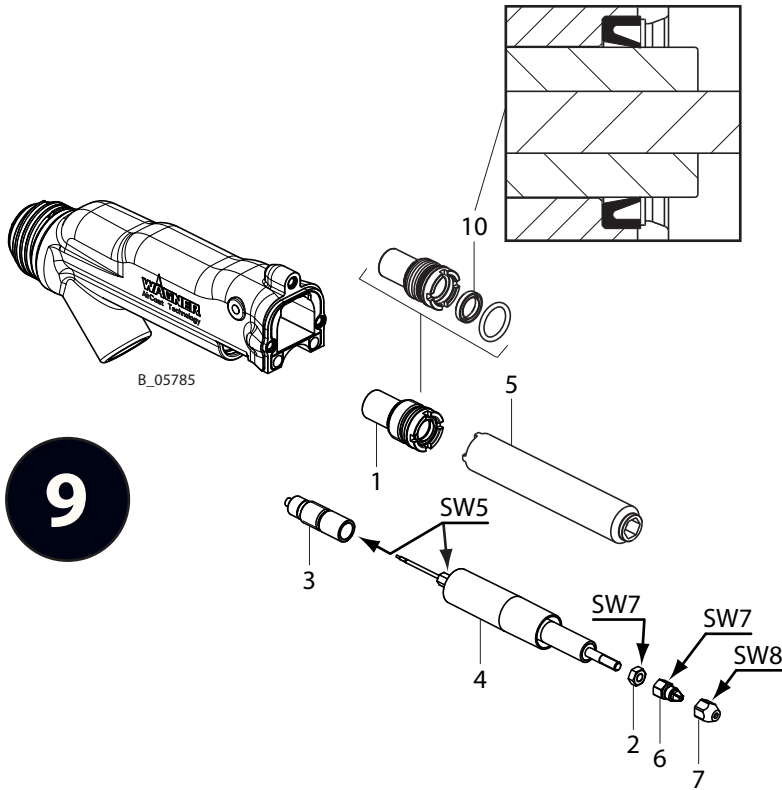



1. Loosen clamping screw (1) with assembly tool (5).
2. Remove valve rod unit (2, 3, 4, 6).
3. **Only as required:**
Remove rod seal (10).
Do not damage the housing in the process.

10.3.3 CLEANING THE PARTS AFTER DISASSEMBLY

ATTENTION

Please note:

- All reusable parts (except for the parts conducting high voltage such as cascade, adapter, plug compl. etc.) should be cleaned thoroughly using a suitable cleaning agent.
- The adapter, plug and all dismantled parts must be clean and dry after cleaning. Care should be taken that these parts remain free of solvents, grease or sweat from the hands (salt water). Clean and mount wearing gloves.
- Spare parts may have safety-relevant properties.
Only repair and replace parts that are listed in the "Spare parts" chapter and that are assigned to the unit.
- Defective parts, O-rings and seal sets must always be re-placed.

	 WARNING
	<p>Incompatibility of cleaning agent and working medium! Risk of explosion and danger of poisoning by toxic gases.</p> <p>→ Examine the compatibility of the cleaning agents and working media on the basis of the safety data sheets.</p>

In Chapter 14 the part numbers for gun spare parts can be found as well as for wearing parts such as seals.

10.3.4 ASSEMBLING THE SPRAY GUN

Assembly aids:		
Pos	Order No.	Description
2 *	9992698	Vaseline white, PHHV II
4	9992511	Loctite® 243

* Use Vaseline sparingly



Valve rod unit:

Set length adjusting measure X with collet chuck (6) and lock with a hexagon nut (2).

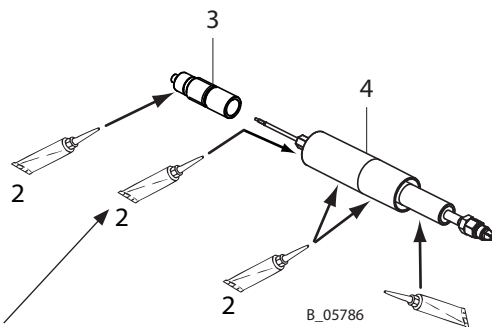
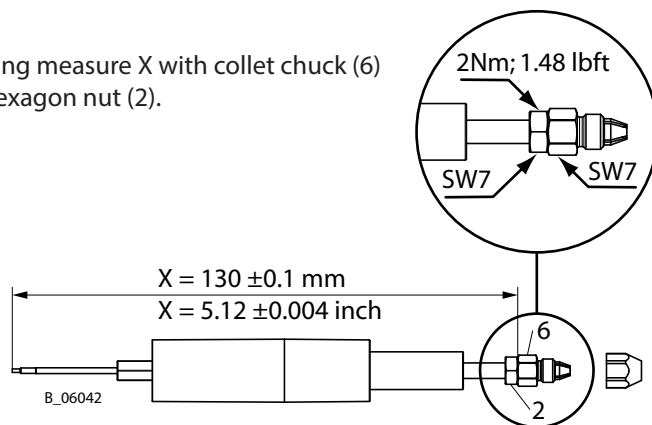

Coat the hollow section with a brush.
Note: avoid the pin and hexagon.

(sparingly)

2

Wear gloves!

The outside thread of the packing (3) must be free of lacquer.

Valve rod unit (4) and packing (3):

- grease,
- slide together,
- screw together

Grease clamping screw (1) and mount using assembly tool (5).

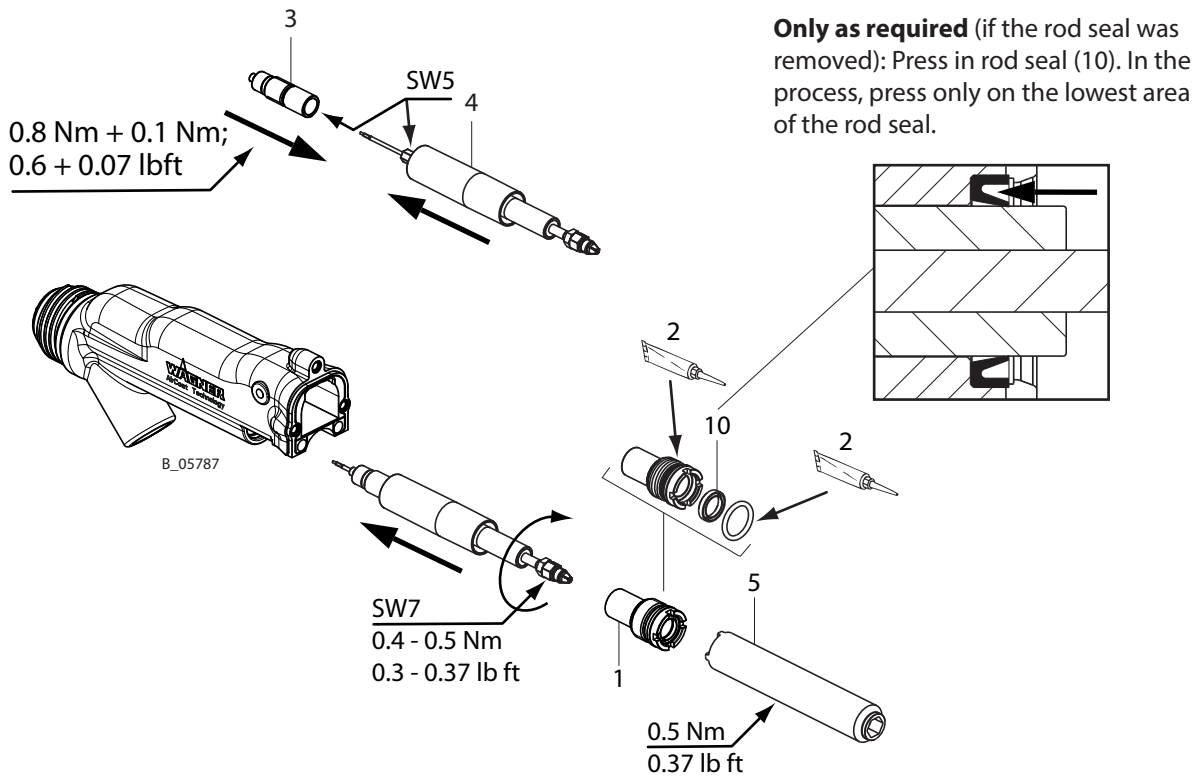

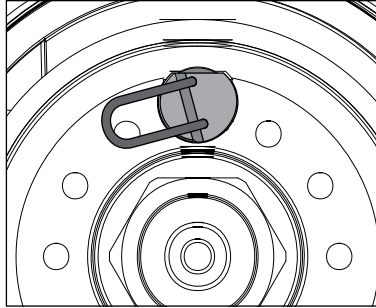

Ensure the correct insertion position and installation direction.

3

Gold contact sleeve (10)
Check whether the gold contact sleeve is located in the end piece (11). Otherwise, insert the sleeve onto the resistance (12).

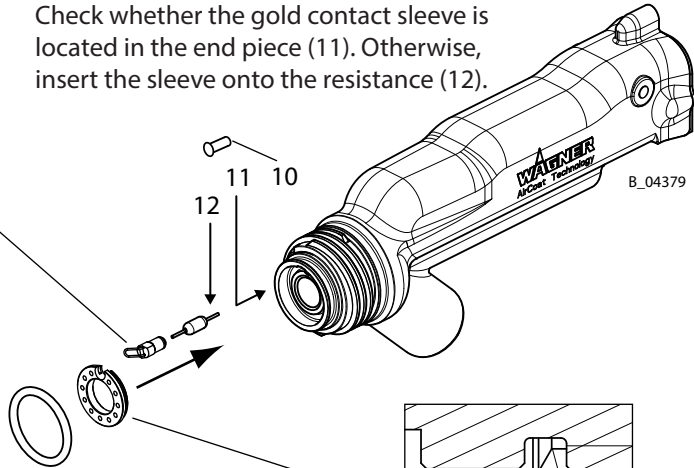

Ensure the correct insertion position.

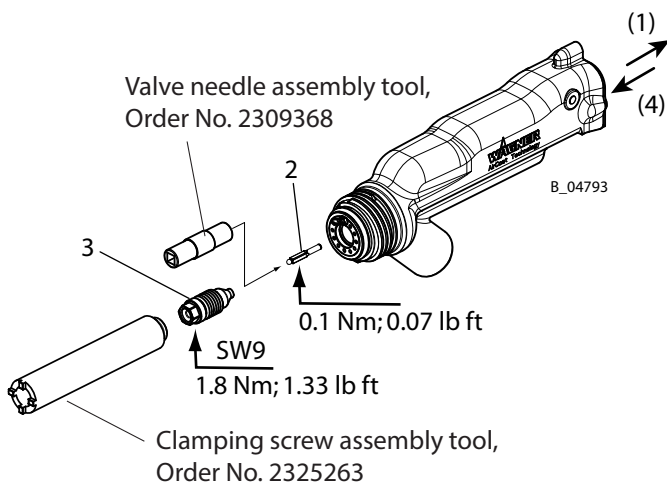
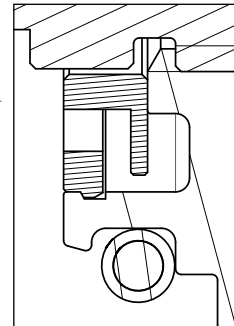

4

1. Move the valve rod to the rear position so that the sealing area does not become scratched (1).
2. Slightly tighten AC valve tip (2) by hand (3 fingers) using an assembly tool.
3. Use socket or ring spanner (no wrench) to tighten the valve housing (3).
4. Slide the valve rod to the forward position (at the valve seat) (4).

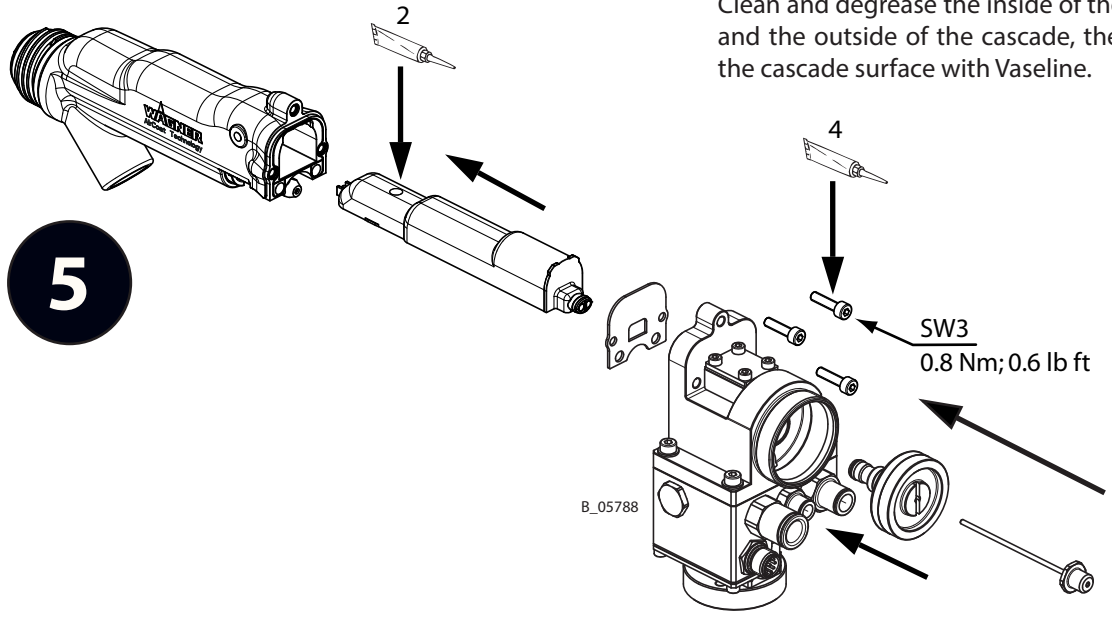

Clean and degrease the inside of the adapter and the outside of the cascade, then grease the cascade surface with Vaseline.

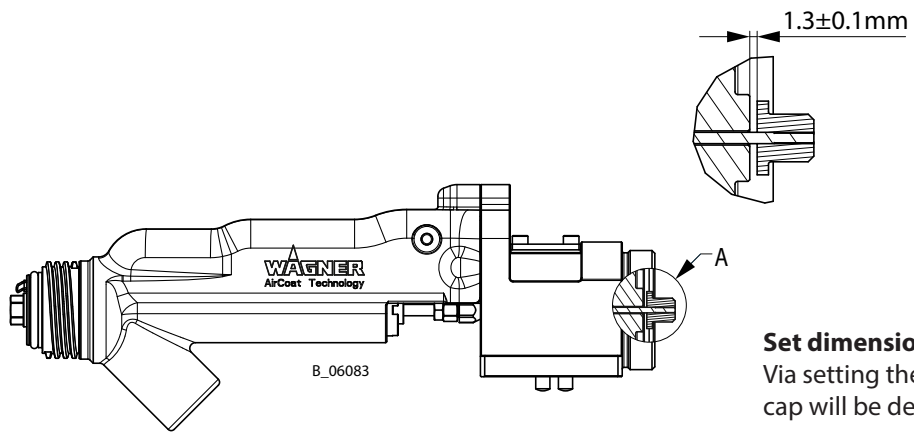

Set dimension 1.3 mm:
Via setting the dimension, soiling of air cap will be decreased.

6

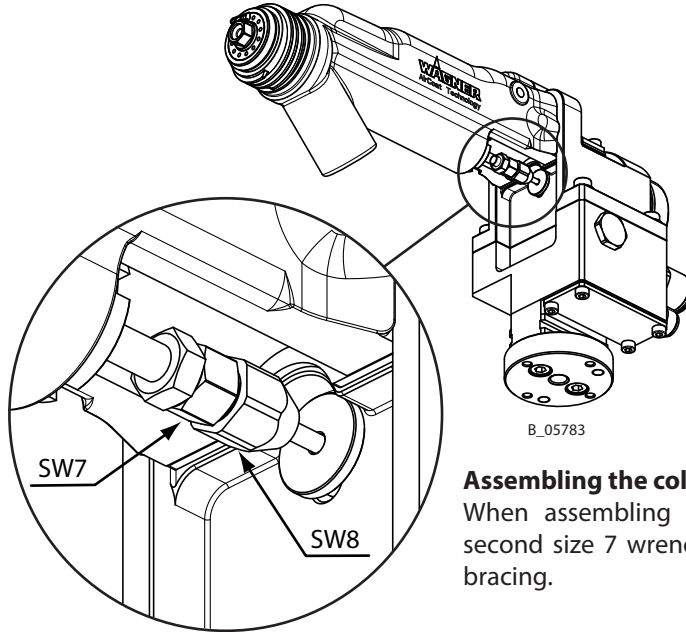

Assembling the collet chuck:

When assembling the collet chuck, a second size 7 wrench must be used for bracing.

7

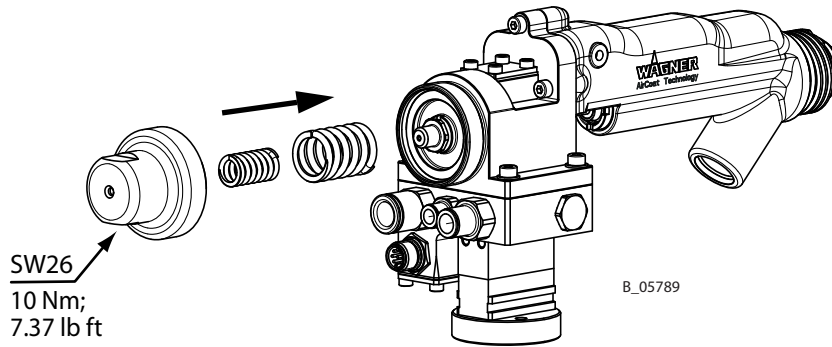

8

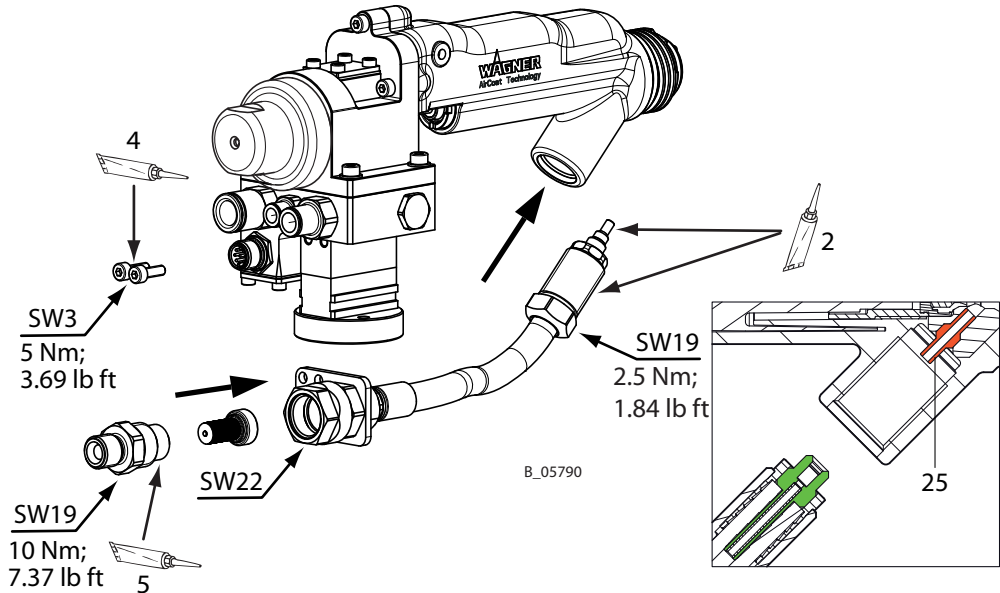

Fitting (25)

Before assembling the product hose, check that no fitting (25) is in the gun adapter! Check the fitting for damage and replace if necessary (Order No. 2338853).

9

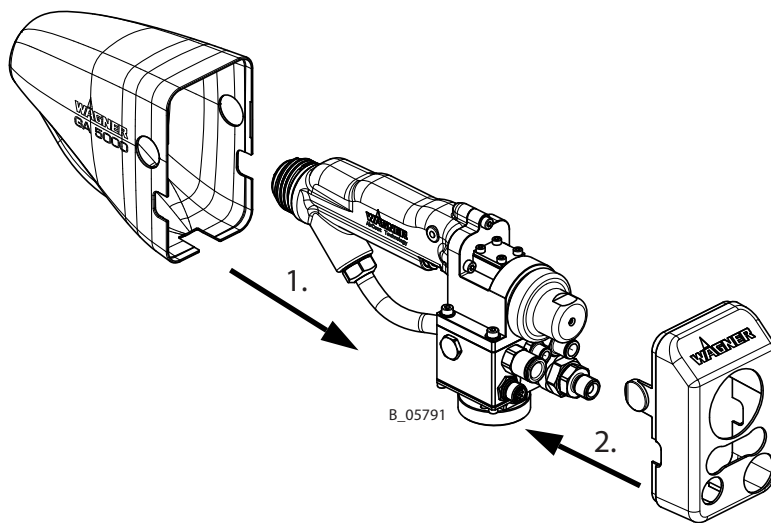

10

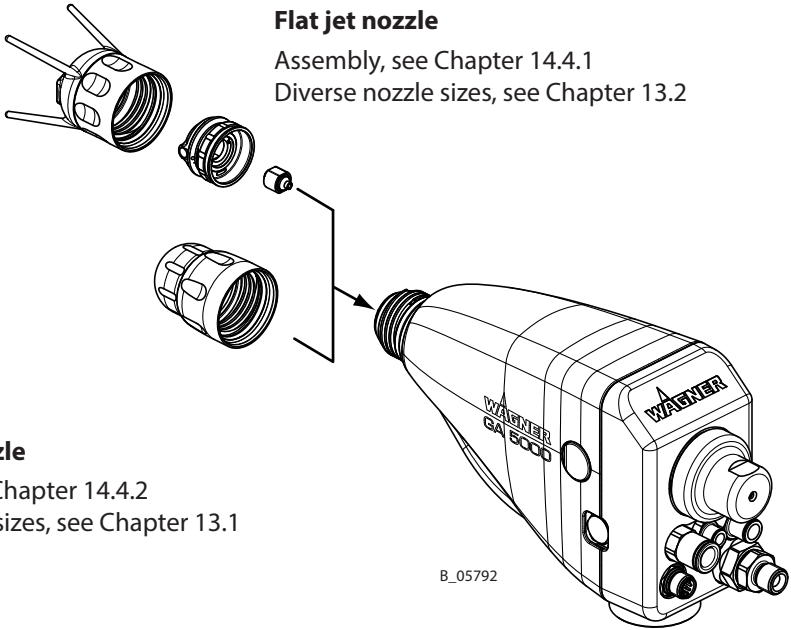

Flat jet nozzle

Assembly, see Chapter 14.4.1
Diverse nozzle sizes, see Chapter 13.2

Round jet nozzle

Assembly, see Chapter 14.4.2
Diverse nozzle sizes, see Chapter 13.1

B_05792

11 FUNCTION TEST AFTER THE REPAIR

After all repairs, the device must be checked for safe condition before recommissioning. The necessary scope of inspection and testing depends on the repair carried out and must be documented by the repair staff.

11.1 CHECKING THE HIGH VOLTAGE

Necessary test equipment:
EPG 5000 control unit and HV 200 high-voltage tester.

High-voltage measurement on spraying gun.

Connect gun cable to control unit. Mount spray gun to grounded gun mounting. Switch on the control unit.

The high voltage should be 60 to 65 kV in dry ambient air. The value can be checked with the display on the control unit (EPG 5000).

Note:

The gun must be clean and dry and must not have any paint or cleaning agent residues. In the case of ambient air with a high air humidity, the measured value can reduce to 50 to 55 kV.

High-voltage measurement with high-voltage tester

Place the ball of the high-voltage tester on the gun electrode and turn on the high voltage. The measured value should be 70 to 80 kV.

Notes:

- When measuring the high voltage the measuring device should be held at arms length as far from the body as possible.
- There should be no chargeable objects within a radius of 1 m; 3.28 ft of the place where the measurements are taken.
- The placing of the measuring ball of the high-voltage measuring device reduces the spraying of the high-voltage electrode. As a result the high-voltage value increases compared to the spraying in the free space.

Disruptive discharge test

Check the gun against ground with the grounding rod. No sparks should be formed.

Note: in the vicinity of the electrode harmless corona discharges can occur.

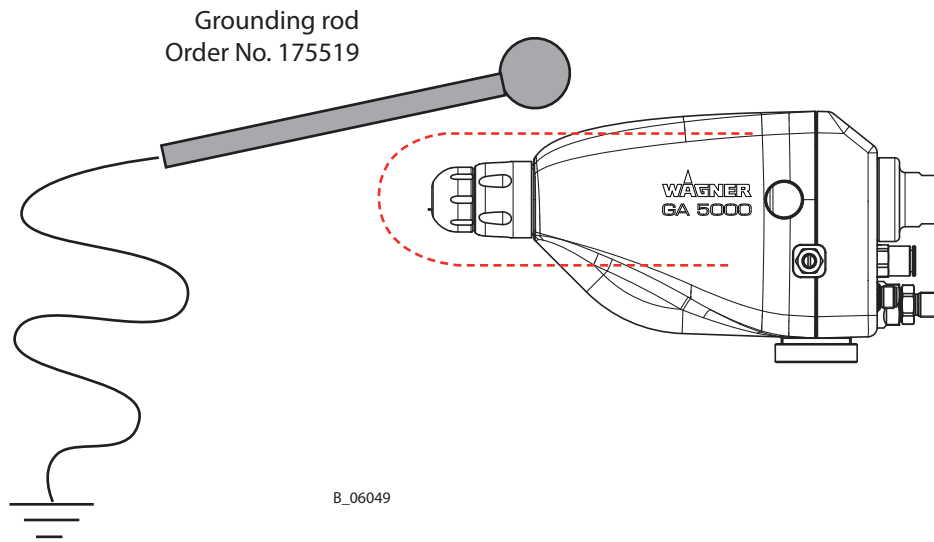

11.2 AIR TEST

GA 5000EAC

Switch off the atomizing and shaping air, switch on control air.

1. 0.4 MPa; 4 bar; 58 psi: The air valve must switch on correctly.
2. 0.8 MPa; 8 bar; 116 psi: Test for air seal.
3. Switch off control air: The air valve must switch off correctly.



11.3 PRODUCT PRESSURE TEST

Connect high-pressure hose to the spray gun.

Test the seal of the spray gun with suitable medium (e.g., flushing agent or Marcol 52) and a maximum pressure of 25 MPa; 250 bar; 3626 psi. Increase the pressure gradually while doing so.

Observe the following gun components:

Product connection, nozzle body, product valve (no post-spraying).

	 DANGER
	Exploding gas / air mixture! Danger to life from flying parts and burns. → Never spray into a closed tank. → Ground the tank.

11.4 TEST OF SPRAY PATTERN

Check spray pattern in accordance with Chapter 7.3.1

12 DISPOSAL

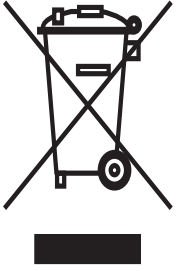
	<p style="text-align: center;">NOTICE</p> <p>Do not dispose of used electrical equipment with household refuse!</p> <p>In accordance with European Directive 2002/96/EC on the disposal of used electrical equipment and its implementation in national law, this product may not be disposed of with the household refuse, but must be recycled in an environmentally correct manner. WAGNER or one of our dealers will take back your used WAGNER electric or electronic equipment and will dispose of it for you in an environmentally-friendly way. Please contact one of our service points, one of our representatives or us directly to arrange this.</p>
---	--

Consumable products

Consumable products (lacquers, adhesives, flushing and cleaning agents) must be disposed of in accordance with all applicable legal requirements.

13 ACCESSORIES

13.1 ROUND JET NOZZLES

13.1.1 ACR 5000 ROUND JET NOZZLE ATTACHMENT

Order No.	Designation
2309883	ACR 5000 round jet nozzle attachment (with nozzle spanner, without AC round jet nozzle insert)

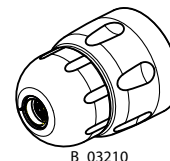

B_03210

13.1.2 AIRCOAT ROUND JET NOZZLE INSERTS

The round jet nozzles are especially suitable for spraying delicate parts, tubes, profiles and complex work pieces.

Order No.	Marking	Jet width mm; inch	Recommended edge filter
132720	11	approx. 250; 10	yellow 200 mesh
132721	12	approx. 250; 10	
132722	13	approx. 250; 10	
132723	14	approx. 250; 10	
132724 *	15	approx. 250; 10	
132725	16	approx. 250; 10	black 100 mesh
132726	17	approx. 250; 10	
132727	18	approx. 250; 10	
132728	19	approx. 250; 10	
132729	20	approx. 250; 10	white 60 mesh
132730	21	approx. 250; 10	
132731	22	approx. 250; 10	

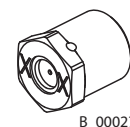

B_00027

* Standard version

Jet width in mm; inches at a distance of 30 cm; 11.8 inches from the object and at a pressure of 10 MPa; 100 bar; 1450 psi.

13.2 FLAT JET NOZZLES

13.2.1 ACF 5000 AIR CAPS (FLAT JET)

Order No.	Designation
2309882	Air cap ACF 5000 - LV suitable for low viscosity products (marked red).
2314203	ACF 5000 air cap - HV suitable for high viscosity products (marked blue).





B_03454

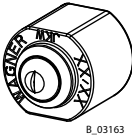

B_03209

13.2.2 ACF5000 AIRCOAT FLAT JET NOZZLES

Order No.	Marking	Drilled hole Ø mm; inch	Spray angle	Application
				
395107 395207 395407	07/10 07/20 07/40	0.18; 0.007	10° 20° 40°	Natural lacquer
395109 395209 395309 395409 395509 395609	09/10 09/20 09/30 09/40 09/50 09/60	0.23; 0.009	10° 20° 30° 40° 50° 60°	Clear lacquer Oils
395111 395211 395311 395411 395511 395611 395811	11/10 11/20 11/30 11/40 11/50 11/60 11/80	0.28; 0.011	10° 20° 30° 40° 50° 60° 80°	Synthetic resin lacquer PVC lacquer
395113 395213 395313 395413 395513 395613 395813	13/10 13/20 13/30 13/40 13/50 13/60 13/80	0.33; 0.013	10° 20° 30° 40° 50° 60° 80°	Lacquers Base coat Primer Filler
395115 395215 395315 395415 395515 395615 395815	15/10 15/20 15/30 15/40 15/50 15/60 15/80	0.38; 0.015	10° 20° 30° 40° 50° 60° 80°	Filler Rust proofing paints
395217 395317 395417 395517 395617 395817	17/20 17/30 17/40 17/50 17/60 17/80	0.43; 0.017	20° 30° 40° 50° 60° 80°	Rust proofing paints Latex paints

Order No.	Marking	Drilled hole Ø mm; inch	Spray angle	Application
				
395219	19/20	0.48; 0.019	20°	Rust proofing paints Latex paints
395319	19/30		30°	
395419	19/40		40°	
395519	19/50		50°	
395619	19/60		60°	
395819	19/80		80°	
395221	21/20	0.53; 0.021	20°	Mica paints Zinc rich paints Rust proofing paints Glue paints
395421	21/40		40°	
395521	21/50		50°	
395621	21/60		60°	
395821	21/80		80°	
395423	23/40	0.58; 0.023	40°	
395623	23/60		60°	
395823	23/80		80°	
395425	25/40	0.64; 0.025	40°	
395625	25/60		60°	
395825	25/80		80°	
395427	27/40	0.69; 0.027	40°	
395627	27/60		60°	
395827	27/80		80°	
395429	29/40	0.75; 0.029	40°	
395629	29/60		60°	
395829	29/80		80°	
395431	31/40	0.79; 0.031	40°	
395631	31/60		60°	
395831	31/80		80°	
395435	35/40	0.90; 0.035	40°	
395635	35/60		60°	
395835	35/80		80°	

13.3 FILTER

Order No.	Designation
3204604	Edge filter, 60 mesh (white)
3204605	Edge filter, 100 mesh (black)
9999002	Edge filter, 200 mesh (yellow)



B_00019

13.4 ELECTRIC CABLES AND HOSES**13.4.1 GUN CABLE**

Order No.	Designation
2339157	Gun cable, 10 m; 32.8 ft
239158	Gun cable, 15 m; 49.2 ft
2339159	Gun cable, 20 m; 65.6 ft
2339160	Gun cable, 25 m; 82.0 ft



B_03218

13.4.2 EXTENSION CABLE FOR GUN CABLE

Order No.	Designation
2339161	Extension cable, 10 m; 32.8 ft
2339162	Extension cable, 20 m; 65.6 ft



B_03218

13.4.3 PRODUCT HOSES, STANDARD

Order No.	Designation
9984573	High-pressure hose-DN4-PN270-¼"NPS-7.5 m-PA
2302374	High-pressure hose DN4-PN270-¼"NPS-10.0m-PA
9984573-15	High-pressure hose-DN4-PN270-¼"NPS-15.0 m-PA
9984573-20	High-pressure hose-DN4-PN270-¼"NPS-20.0 m-PA



13.4.4 PRODUCT HOSES, LOWR

Order No.	Designation
2367212	Product hose, GA EAC LowR 7.5 m
2367213	Product hose, GA EAC LowR 10 m
2367214	Product hose, GA EAC LowR 15 m
2367215	Product hose, GA EAC LowR 20 m



13.4.5 PRODUCT HOSE, 1.5 MM

Order No.	Designation
2367217	Product hose (ID = 1.5 mm)

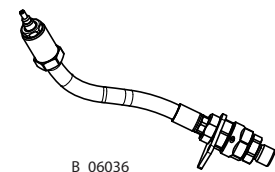

13.4.6 AIR HOSES

Order No.	Designation
9982035	Air hose, red Ø 6 mm, per meter
9982077	Air hose, green Ø 8 mm, per meter
9987095	Air hose, blue Ø 10 mm, per meter

13.5 MISCELLANEOUS

Order No.	Designation
259010	High-voltage tester, HV 200 N
2326041	Paint resistance meter
999080	Wet film thickness gauge
50342	Viscosity cup, DIN 4 mm; 0.16 inches
2309368	Valve needle assembly tool
128901	Nozzle spanner, ACR
2325263	Clamping screw assembly tool

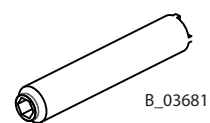
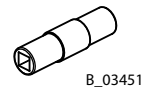
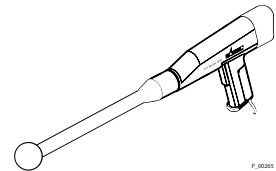

Order No.	Designation
380941	Standard gun holder, 180 mm; Ø 16 mm, 7.1 inches; Ø 0.63 inches
2314079	Cefla adapter plate
380942	Rotary gun holder (standard)
380945	Rotary holder, 40/40/5
380943	Complete swivel drive
380944	Cross clamp for swivel drive
2370869	Robot connection, GA 5000

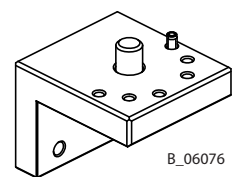
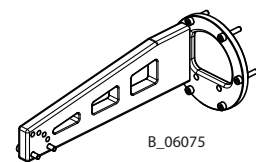
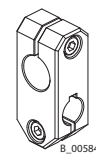
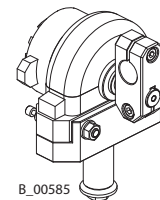
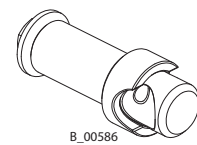
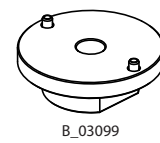
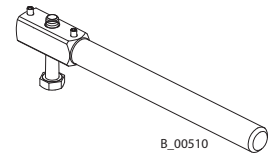

14 SPARE PARTS

14.1 HOW CAN SPARE PARTS BE ORDERED?

Always supply the following information to ensure delivery of the right spare part:

Order number, designation and quantity

The quantity need not be the same as the number given in the quantity column "Stk" on the list. This number merely indicates how many of the respective parts are used in each component.

The following information is also required to ensure smooth processing of your order:

- Address for the invoice
- Address for delivery
- Name of the person to be contacted in the event of any queries
- Type of delivery (normal mail, express delivery, air freight, courier, etc.)



Identification in spare parts lists.

Explanation of column "K" (labeling) in the following spare parts lists:

- ◆ Wearing parts

Note: These parts are not covered by warranty terms.

- Not part of standard equipment, available, however, as additional extra.

	 DANGER
	<p>Incorrect maintenance/repair! Danger to life and equipment damage.</p> <ul style="list-style-type: none"> → Only a WAGNER service center or a suitably trained person may carry out repairs and replace parts. → Only repair and replace parts that are listed in the "Spare parts" chapter and that are assigned to the unit. → Before all work on the device and in the event of work interruptions: <ul style="list-style-type: none"> - Switch off the energy supply and the compressed air supply. - Relieve the pressure from the spray gun and device. - Secure the spray gun against actuation. → Observe the operating and service manual for all work.

14.2 GA 5000EAC IC SPRAY GUN

Spare parts list for GA 5000EAC IC

Pos	K	Stk	Order No.	Designation
1		1	2360898	GA 5000EAC IC
2		1	2315775	Union nut AC, complete
3		1	-	Adapter, complete GA 5000EAC (For details, see Chapter 14.2.1)
4		1	2307232	Adapter seal

◆ = Wearing part

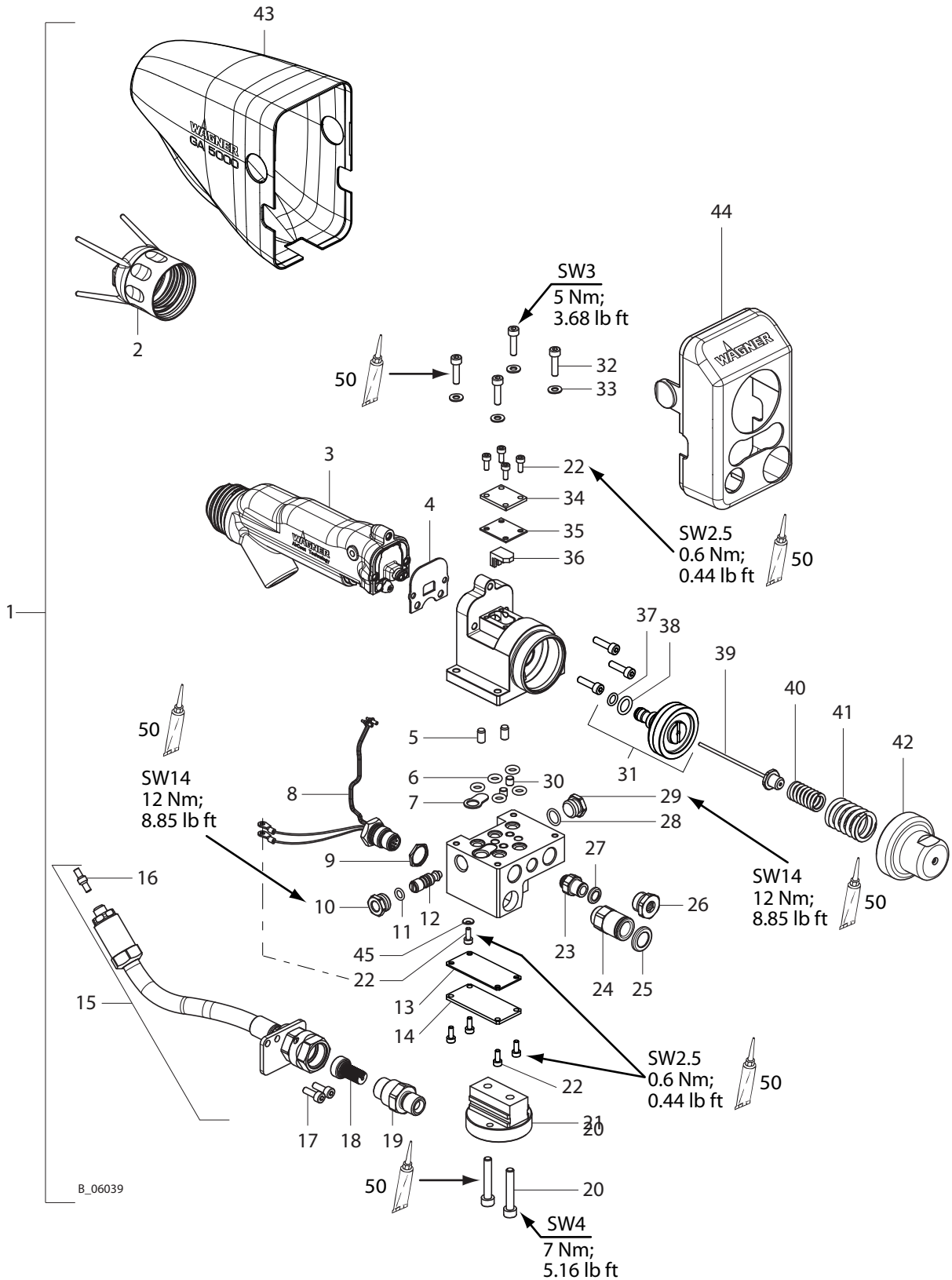

Spare parts list for GA 5000EACIC

Pos	K	Stk	Order No.	Designation
5		2	9930128	Parallel pin
6	◆	5	9974265	O-ring
7	◆	1	2360689	Seal
8		1	2360813	Cable, complete (only for WAGNER Service Department)
9		1	2357712	Locknut
10		1	2307739	Mounting nut
11	◆	1	9971388	O-ring
12		1	2307868	Round spray jet reduction
13	◆	1	2357738	Seal
14	◆	1	2357739	Cover
15		1	2386373	Product hose, complete GA AC
16	◆	1	2338853	Connecting fitting AC
17		2	9900353	Hexagon socket cylinder head screw
18		1	3204605	Edge filter, 100 mesh
19		1	2308764	Filter socket AC
20		2	9900329	Hexagon socket cylinder head screw
21	◆	1	2357737	Mounting bracket
22		9	9906029	Hexagon socket cylinder head screw
23		1	9998090	Straight screw-in fitting
24		1	9998987	Straight threaded fitting
25		1	9998770	Coding ring blue, d10
26		1	9998274	Threaded plug, G1/4"
27		1	9998995	Coding ring red, d6
28	◆	1	9974089	O-ring
29		1	2358895	Sealing plug
30		2	2360690	Plug
31		1	2313501	Complete piston IC
32		7	9900308	Hexagon socket cylinder head screw
33		4	9920104	Washer
34		1	2357167	Lock plate
35		1	2357166	Seal
36		1	2357164	Contact holder
37	◆	1	248314	O-ring
38	◆	1	9971025	O-ring
39		1	2371130	Pull rod
40	◆	1	2309945	Cylindrical helical spring
41	◆	1	9998991	Cylindrical helical spring
42		1	2307741	End cap short
43		1	2365237	Cover, labeled
44		1	2365238	Lid labeled, EACIC
45		1	2338526	Contact spacer
50		1	9992511	Loctite® 243
		1	2369320	Service set Air/Controller, GA 5000E

◆ = Wearing part

14.2.1 GA 5000EAC - ADAPTER

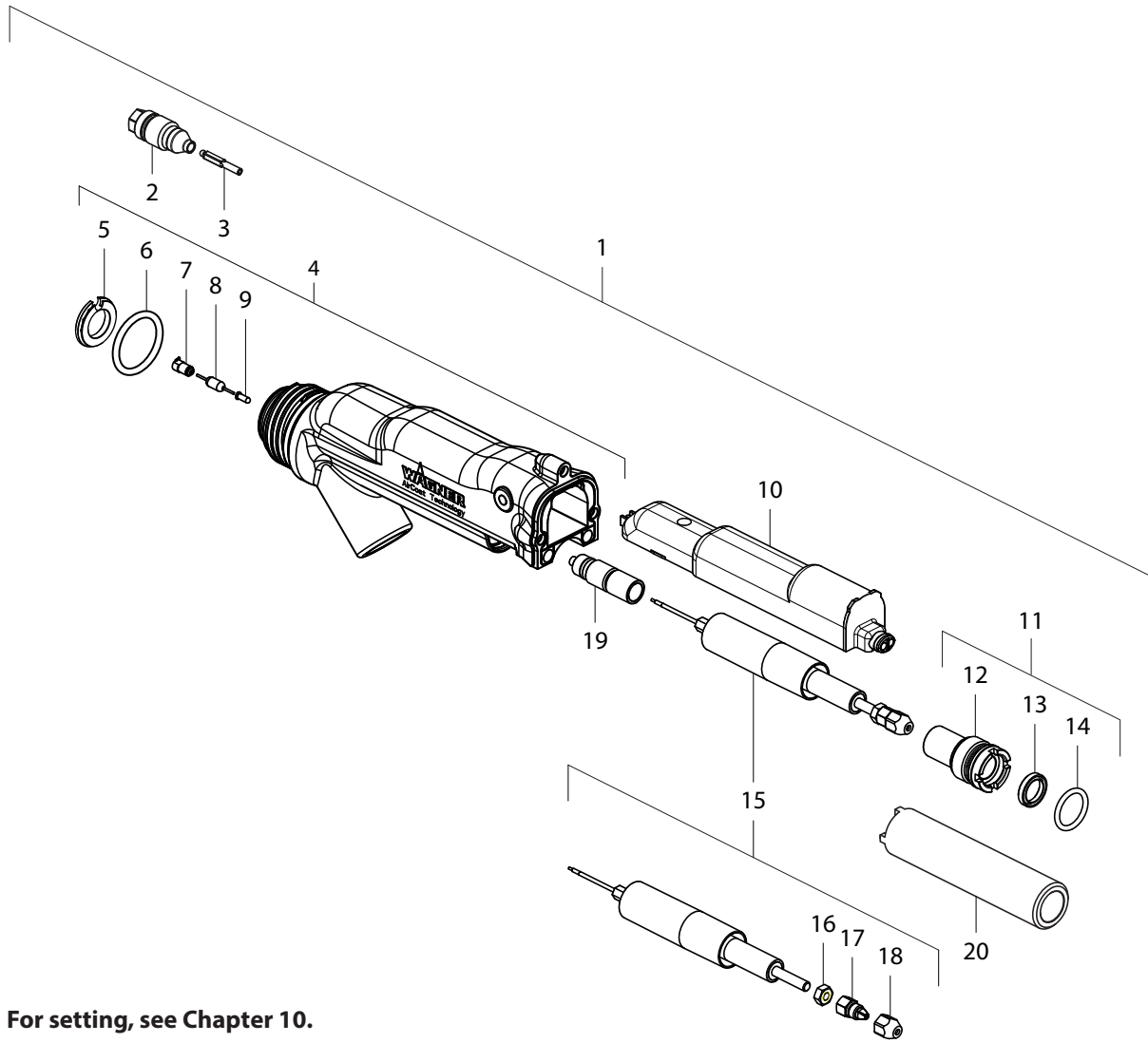

For setting, see Chapter 10.

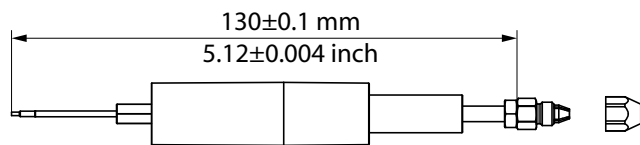

B_06046

Spare parts list for adapter

Pos	K	Stk	Order No.	Designation
1		1	-	Adapter, complete GA 5000EAC
2		1	2312175	Valve housing AC, complete
3	◆	1	2312186	Valve needle AC, complete
4		1	2357170	Adapter, GA 5000EAC
5		1	2313314	Air manifold ring, AC
6	◆	1	2307180	O-ring, sheathed
7	◆	1	2314283	Contacting, AC
8	◆	1	9952777	High resistance, bare
9		1	9960808	Socket contact component (gold contact sleeve)
10		1	2312181	Cascade, complete
11		1	2357665	Clamping screw valve rod, complete
12		1	2307062	Clamping screw valve rod
13	◆	1	2311562	Rod seal
14	◆	1	9974166	O-ring
15		1	2369017	Valve rod unit, AC
16		1	9910108	Hexagon nut
17		1	2357740	Collet chuck
18		1	2357741	Tension nut
19		1	2357106	Packing, complete
20		1	2325263	Clamping screw assembly tool
		1	2369015	Service set, GA 5000EAC adapter

◆ = Wearing part

★ = Included in service set

● = Not part of the standard equipment but available as a special accessory.

14.3 GA 5000EACEC SPRAY GUN

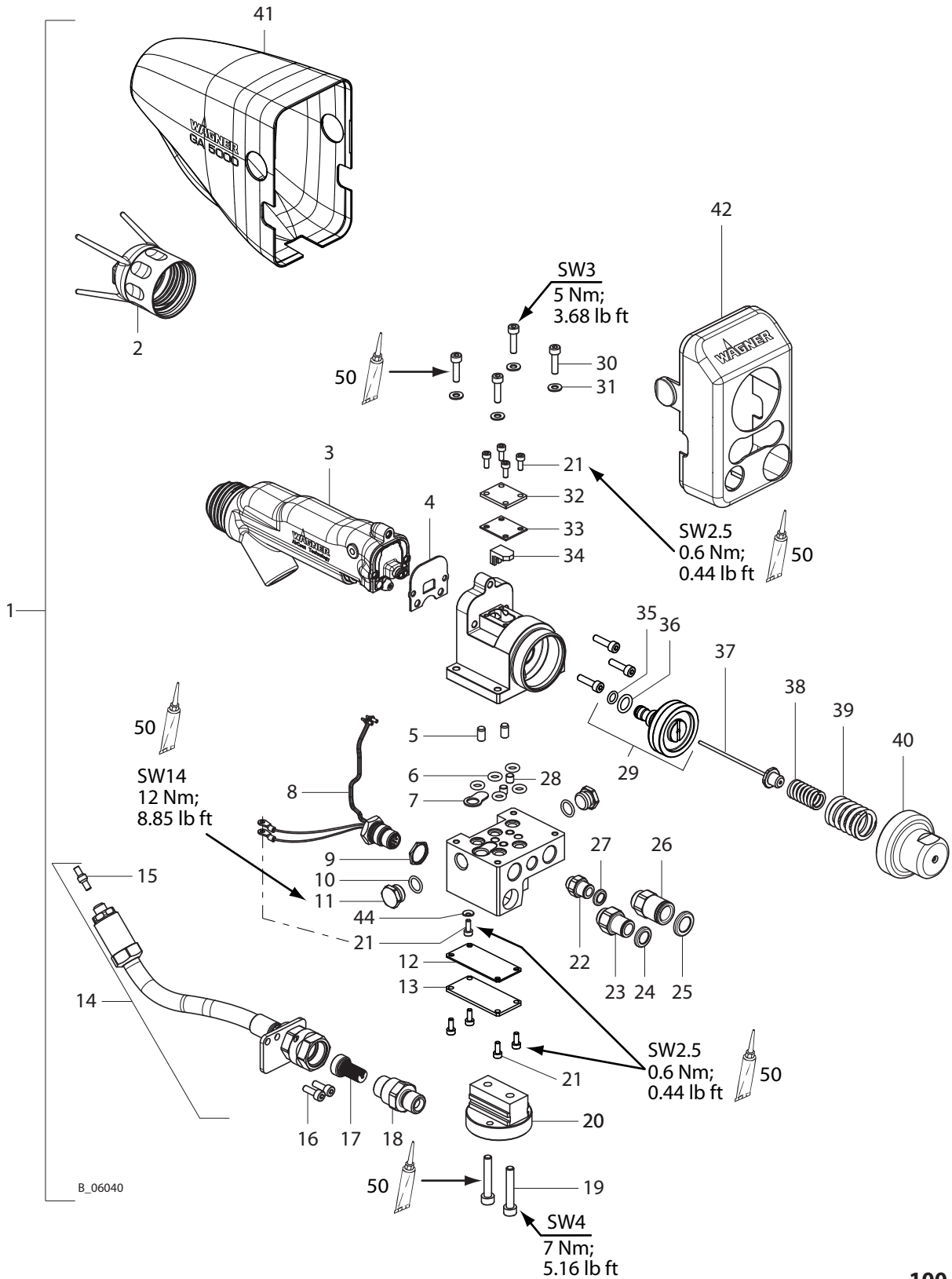

B_06040

Spare parts list for GA 5000EACEC

Pos	K	Stk	Order No.	Designation
1		1	2360899	GA 5000EACEC
2		1	2315775	Union nut AC, complete
3		1	-	Adapter, complete GA 5000EAC (For details, see Chapter 14.2.1)
4		1	2307232	Adapter seal
5		2	9930128	Parallel pin
6	◆	5	9974265	O-ring
7	◆	1	2360689	Seal
8		1	2360813	Cable, complete (only for WAGNER Service Department)
9		1	2357712	Locknut
10	◆	2	9974089	O-ring
11		1	2358895	Sealing plug
12	◆	1	2357738	Seal
13	◆	1	2357739	Cover
14		1	2386373	Product hose, complete GA AC
15	◆	1	2338853	Connecting fitting, AC
16		2	9900353	Hexagon socket cylinder head screw
17		1	3204605	Edge filter, 100 mesh
18		1	2308764	Filter socket, AC
19		2	9900329	Hexagon socket cylinder head screw
20	◆	1	2357737	Mounting bracket
21		9	9906029	Hexagon socket cylinder head screw
22		1	9998090	Straight screw-in fitting
23		1	9998254	Straight screw-in fitting
24		1	9998616	Coding ring green, d8
25		1	9998770	Coding ring blue, d10
26		1	9998987	Straight threaded fitting
27		1	9998995	Coding ring red, d6
28		2	2360690	Plug
29		1	2313501	Complete piston, IC
30		7	9900308	Hexagon socket cylinder head screw
31		4	9920104	Washer
32		1	2357167	Lock plate
33		1	2357166	Seal
34		1	2357164	Contact holder
35	◆	1	248314	O-ring
36	◆	1	9971025	O-ring
37		1	2371130	Pull rod
38	◆	1	2309945	Cylindrical helical spring
39	◆	1	9998991	Cylindrical helical spring
40		1	2307741	End cap short
41		1	2365237	Cover, labeled
42		1	2365244	Lid labeled, EACEC
44		1	2338526	Contact spacer
50		1	9992511	Loctite® 243
		1	2369320	Service set Air/Controller

◆ = Wearing part

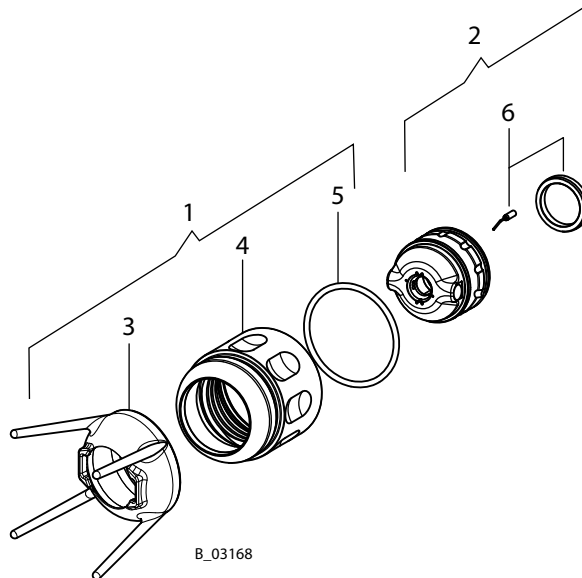
14.4 ACCESSORIES SPARE PARTS LISTS**14.4.1 FLAT JET NOZZLES**

Spare parts list for flat jet nozzles

Pos	K	Stk	Order No.	Designation
1		1	2315775	Union nut AC, complete
2		1	2309882	Air cap, ACF 5000 - LV (red)
2		1	2314203	Air cap, ACF 5000 - HV (blue)
3	◆	1	2311777	Nozzle guard, AC
4	◆	1	2311776	Union nut, AC
5	◆	1	2311217	O-ring, sheathed
6	◆	1	2319525	Flat electrode set

◆ = Wearing part

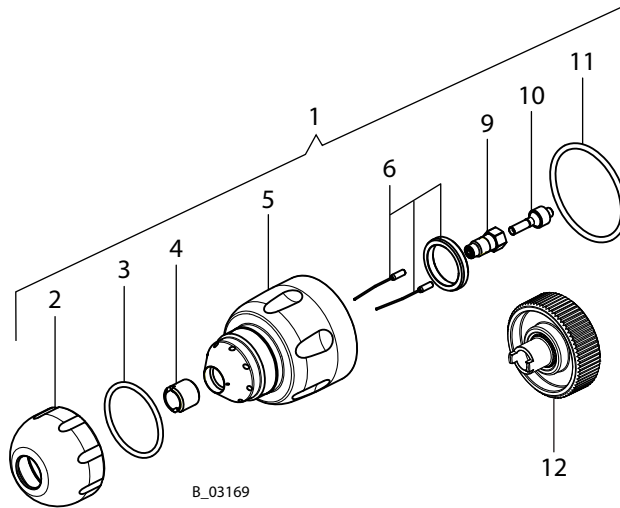
14.4.2 ACR 5000 ROUND JET NOZZLE ATTACHMENT

Spare parts list for ACR 5000 round jet nozzle attachment

Pos	K	Stk	Order No.	Designation
1		1	2309883	Round jet nozzle attachment, ACR 5000
2		1	2307220	Nozzle nut
3	◆	1	2315310	O-ring
4	◆	1	132351	Nozzle screwed connection holder
5		1	2307219	Nozzle body
6	◆	1	2319526	Round electrode set
9	◆	1	132516	Nozzle screw joint, complete
10	◆	1	2307216	Sealing fitting
11	◆	1	2311217	O-ring
12		1	128901	Nozzle wrench, complete

◆ = Wearing part

15 WARRANTY AND CONFORMITY DECLARATIONS

15.1 IMPORTANT NOTES REGARDING PRODUCT LIABILITY

As a result of an EC regulation effective from January 1, 1990, the manufacturer shall only be liable for his product if all parts originate from him or are approved by him, and if the devices are properly mounted, operated and maintained.

The manufacturer will not be held liable or will only be held partially liable if third-party accessories or spare parts have been used.

With genuine WAGNER accessories and spare parts, you have the guarantee that all safety regulations are complied with.

15.2 WARRANTY CLAIM

Full warranty is provided for this device:

We will at our discretion repair or replace free of charge all parts which within 24 months in single-shift, 12 months in 2-shift or 6 months in 3-shift operation from date of receipt by the purchaser are found to be wholly or substantially unusable due to causes prior to the sale, in particular faulty design, defective materials or poor workmanship.

The type of warranty provided is such that the device or individual components of the device are either replaced or repaired as we see fit. The resulting costs, in particular shipping charges, road tolls, labour and material costs will be borne by us except where these costs are increased due to the subsequent shipment of the device to a location other than the address of the purchaser.

We do not provide warranty for damage that has been caused or contributed to for the following reasons:

Unsuitable or improper use, faulty assembly or commissioning by the purchaser or a third party, normal wear, negligent handling, defective maintenance, unsuitable coating products, substitute products and the influence of chemical, electrochemical or electrical agents, except when the damage is attributable to us.

Abrasive coating products such as red lead, emulsions, glazes, liquid abrasives, zinc dust paints and so forth reduce the service life of valves, packings, spray guns, nozzles, cylinders, pistons etc. Signs of wear traced back to these products are not covered by this warranty. Components that have not been manufactured by WAGNER are subject to the original warranty of the manufacturer.

Replacement of a component does not extend the period of warranty of the device.

The device should be inspected immediately upon receipt. To avoid losing the warranty, we or the supplier company are to be informed in writing about obvious faults within 14 days upon receipt of the device.

We reserve the right to have the warranty compliance met by a contracting company.

The services provided by this warranty are dependent on evidence being provided in the form of an invoice or delivery note. If the examination discovers that no warranty claim exists, the costs of repairs are charged to the purchaser.

It is clearly stipulated that this warranty claim does not represent any constraint on statutory regulations or regulations agreed to contractually in our general terms and conditions.

15.3 EU DECLARATION OF CONFORMITY

EU Declaration of Conformity as defined by Atex-directive 2014/34/EU.

Herewith we declare that the supplied version of

Electrostatic automatic spraying system		
EPG 5000	GA 5000EA	GA 5000EAC



complies with the following guidelines:

2006/42/EC	2014/34/EU	2014/30/EU
2011/65/EU	2012/19/EU	

Applied standards, in particular:

EN ISO 12100: 2010	EN 1953:2013	EN 60204-1: 2006 +A1: 2009 +B: 2010
EN 60529: 1991 +A1: 2000 +A2: 2013	EN 50050-1:2013	EN 50176:2009
EN 61000-6-2: 2005 +B: 2011	EN 61000-6-4: 2007 +A1: 2011	EN ISO/IEC 80079-34: 2011

Applied national technical standards and specifications, in particular:

DGUV Information 209-052	DGUV regulation 100-500 Chapter 2.29	DGUV regulation 100-500 Chapter 2.36
--------------------------	---	---

EC Type Examination Certificate:

SIRA 16 ATEX5290X by SIRA Certification Unit 6 Hawarden Industrial Park, Hawarden, CH5 3US United Kingdom
--

Identification:

Control unit **CE**₀₁₀₂ **Ex** II (2) G X
SIRA 16 ATEX5290X

Spray gun: **CE**₀₁₀₂ **Ex** II 2 G 0.24mJ X
SIRA 16 ATEX5290X

EU Declaration of Conformity

The EU Declaration of Conformity is enclosed with this product. If needed, further copies can be ordered through your WAGNER dealer by specifying the product name and serial number.

Order number:

2360925

OPERATING MANUAL

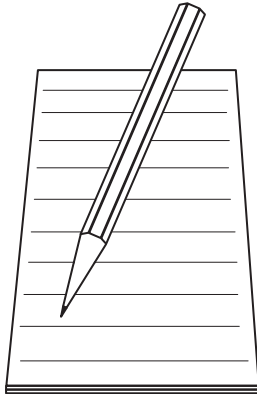

A series of horizontal lines for writing, starting from the top right and extending across the page.

WAGNER



Order No. 2360922

Version 09/2016

Germany

J. Wagner GmbH

Otto-Lilienthal-Str. 18

Postfach 1120

D- 88677 Markdorf

Phone +49/ (0)7544 / 5050

Telefax +49/ (0)7544 / 505200

E-mail service.standard@wagner-group.com

Switzerland

Wagner International AG

Industriestrasse 22

CH- 9450 Altstätten

Phone +41/ (0)71 / 757 2211

Telefax +41/ (0)71 / 757 2222

More contact addresses on the internet at:

www.wagner-group.com

Company / Locations / WAGNER worldwide

Subject to changes without notice